

A REAL TIME POWER MONITORING SYSTEM

HENG FOOK LIANG

**A project report submitted in partial fulfilment of the
requirements for the award of the degree of
Bachelor (Hons.) of Electronics and Communications Engineering**

**Faculty of Engineering and Science
Universiti Tunku Abdul Rahman**

May 2011

DECLARATION

I hereby declare that this project report is based on my original work except for citations and quotations which have been duly acknowledged. I also declare that it has not been previously and concurrently submitted for any other degree or award at UTAR or other institutions.

Signature : _____

Name : _____

ID No. : _____

Date : _____

APPROVAL FOR SUBMISSION

I certify that this project report entitled “**A REAL TIME POWER MONITORING SYSTEM**” was prepared by **HENG FOOK LIANG** has met the required standard for submission in partial fulfilment of the requirements for the award of Bachelor (Hons.) of Electronics and Communications Engineering at Universiti Tunku Abdul Rahman.

Approved by,

Signature : _____

Supervisor: Dr. Lew Kim Luong

Date : _____

The copyright of this report belongs to the author under the terms of the copyright Act 1987 as qualified by Intellectual Property Policy of University Tunku Abdul Rahman. Due acknowledgement shall always be made of the use of any material contained in, or derived from, this report.

© 2010, Heng Fook Liang. All right reserved.

Specially dedicated to
my beloved grandmother, mother and father

ACKNOWLEDGEMENTS

I would like to thank everyone who had contributed to the successful completion of this project. I would like to express my gratitude to my research supervisor, Dr. Lew Kim Luong for his invaluable advice, guidance and his enormous patience throughout the development of the research.

In addition, I would also like to express my gratitude to my loving parent and friends who had helped and given me encouragement in this project.

A REAL TIME POWER MONITORING SYSTEM

ABSTRACT

Real time power monitoring system relate generally to the field of electric energy consumption and more specifically to the power meter having embedded intelligence to decompose occupy current and voltage signals into specific constituent energy consumption for the home appliances in real time. In order to help consumers monitor the energy usage of their electrical appliance, a real time power monitoring system is used to inform consumers about the current/ power consumption of the individual electrical appliance to avoid energy wastage. There are 6 sub modules in the system: Current sensor module, voltage regulate module, voltage inverter module, op-amp amplifier module, Bridge rectifier module and control unit. The current measured by the current sensor module will be converted into digital signal by control unit (PIC) using Analogue-to-Digital conversion. Voltage regulate module is designed to regulated a constant voltage level from 9V battery to 5V which used for operated the control unit. Voltage inverter module is needed to provide negative DC which is provided to start up the op-amp for the purpose of stepping up the current sensor output signal to ensure it is in the sufficient range to power up the Bridge Rectifier module for AC to DC conversion. Lastly, Control unit will be performing various functions such as power consumption calculation, providing alert signal and display total power consumption through the LCD display. Real time powers monitoring systems is developed and perform in the current measurement range of 3A to 10A which is appropriate operating range of commercial home electrical appliances.

TABLE OF CONTENTS

| | |
|--|-------------|
| DECLARATION | ii |
| APPROVAL FOR SUBMISSION | iii |
| ACKNOWLEDGEMENTS | vi |
| ABSTRACT | vii |
| TABLE OF CONTENTS | viii |
| LIST OF TABLES | xii |
| LIST OF FIGURES | xiii |
| LIST OF SYMBOLS / ABBREVIATIONS | xvi |
| LIST OF APPENDICES | xvii |

CHAPTER

| | | |
|----------|---|-----------|
| 1 | INTRODUCTION | 18 |
| | 1.1 Project Background and Motivation | 18 |
| 1 | 18 | |
| | 1.2 Aims and objectives | 19 |
| | 1.3 Project scope and brief description | 20 |
| | 1.4 Problem Statement | 21 |
| | 1.5 Thesis outline | 21 |
| 2 | LITERATURE REVIEW | 23 |
| | 2.1 Background of power monitoring system | 23 |
| | 2.2 The Effectiveness of Power Consumption Feedback System. | 25 |
| | 2.3 Power supply in Malaysia | 26 |

| | | |
|--------|---|----|
| 2.3.1 | Plug, main voltage and frequency in Malaysia | 26 |
| 2.4 | Current Capacity Status | 27 |
| 2.5 | Steady State Supply Voltage performance in Malaysia | 27 |
| 2.6 | Important Parameters of Power. | 28 |
| 2.6.1 | Real, reactive, and apparent power | 28 |
| 2.7 | Power factor | 30 |
| 2.8 | Methods of Measurement current | 32 |
| 2.8.1 | Sense resistor | 33 |
| 2.8.2 | Current Transformer | 34 |
| 2.8.3 | Hall Effect Sensor | 35 |
| 2.8.4 | Closed loop Hall Effect Sensor | 36 |
| 2.9 | The benefits and drawbacks of the different current sensor technologies | 37 |
| | Sense resistor | 37 |
| | Current Transformer | 37 |
| | Hall Effect Sensor | 37 |
| 2.10 | Ideal of Analog to digital conversion | 38 |
| 2.11 | The concept of Bridge Rectifier works (conversion between AC to DC) | 39 |
| 2.11.1 | Peak loss of the rectifier | 40 |
| 2.11.2 | Rectifier Output Smoothing | 41 |
| 2.12 | Ready product in the Market | 41 |
| 2.12.1 | P3 International - P4400 Kill A Watt | 42 |
| 2.12.2 | Brennenstuhl PM230 Electricity Meter | 43 |
| 2.12.3 | Watts up? .Net | 44 |
| 2.12.4 | TED 5004-C | 46 |
| 2.13 | Hardware and component | 47 |
| 2.13.1 | Current Transducer (LTS-25-NP) | 47 |
| 2.13.2 | Current Transformer (MX3B-30/5A) | 49 |
| 2.13.3 | Microcontroller (PIC 16F877A) | 50 |
| 2.14 | Voltage regulator | 51 |
| 2.14.1 | 5V Dc voltage regulator (LM7805) | 51 |
| 2.14.2 | LM317 3-Terminal Adjustable Regulator | 52 |
| 2.15 | Bridge Rectifier | 52 |

| | | |
|----------|---|-----------|
| 2.16 | LM 555 Timer | 53 |
| 2.17 | Operational amplifier (UA741) | 54 |
| 2.18 | LCD Display Module | 54 |
| 2.19 | Software | 55 |
| | 2.19.1 NI Ultiboard | 55 |
| 2.20 | NI Multisim | 56 |
| 2.21 | Proteus VSM | 57 |
| 2.22 | MPLAB IDE | 58 |
| 2.23 | CCS C Compiler | 59 |
| 3 | METHODOLOGY | 60 |
| 3.1 | First Prototype System Overview | 60 |
| 3.2 | First Prototype Hardware implementation | 61 |
| | 3.2.1 First Prototype Current sensor module | 61 |
| | 3.2.2 Voltage regulate module | 63 |
| | 3.2.3 First prototype Control Unit overview | 64 |
| | 3.2.4 First prototype schematic | 65 |
| | 3.2.5 First prototype review | 65 |
| 3.3 | Second prototype Hardware implementation | 66 |
| | 3.3.1 Second prototype system overview | 66 |
| | 3.3.2 Second prototype Current Sensor with Bridge Rectifier Module | 67 |
| | 3.3.3 Second prototype Voltage inverter | 68 |
| | 3.3.4 Second prototype review | 68 |
| 3.4 | Third prototype hardware implementation | 69 |
| | 3.4.1 Third prototype System overview | 69 |
| | 3.4.2 Third prototype Control Unit | 70 |
| 3.5 | Software implementation | 71 |
| 4.1 | Individual Module Hardware Testing | 77 |
| | 4.1.1 Current Sensor Module Testing | 77 |
| | 4.1.2 Op-amp amplifier module and ± 9 V voltage inverter module testing | 83 |
| | 4.1.3 Bridge Rectifier module testing | 87 |

| | | |
|----------|-----------------------------|-----------|
| | | xi |
| 4.2 | Combination modules testing | 89 |
| 4.3 | Final Design Testing | 91 |
| 4.4 | Performance and Efficiency | 91 |
| 5 | CONCLUSION | 93 |
| 5.1 | Limitation of the product | 93 |
| 5.2 | Improvement | 95 |
| 5.3 | Conclusion | 96 |
| | REFERENCES | 97 |
| | APPENDIX | 99 |

LIST OF TABLES

| TABLE | TITLE | PAGE |
|--------------|---|-------------|
| Table 2-1 | Steady state voltage fluctuation limits under normal condition | 28 |
| Table 2-2 | Steady state voltage fluctuation limits under contingency condition | 28 |
| Table 2-3 | Average power factor based on killawatt meter (Arora, 2010) | 32 |
| Table 2-4 | the benefits and drawbacks of the different current sensor technologies | 37 |
| Table 3-1 | Project Time Scheduling | 101 |
| Table 4-1 | Result of current transducer testing 1 | 78 |
| Table 4-2 | Testing on current transducer | 80 |
| Table 4-3 | Result of increasing burden resistance | 81 |
| Table 4-4 | Result of increase primary winding | 82 |
| Table 4-5 | Amplifier testing 1 | 84 |
| Table 4-6 | Amplifier testing 2 | 85 |
| Table 4-7 | inverter output | 85 |
| Table 4-8 | Amplified output with voltage inveter module | 86 |
| Table: 4-9 | Voltage drop testing between diode | 87 |
| Table 4-10 | Several of capacitance testing | 88 |

LIST OF FIGURES

| FIGURE | TITLE | PAGE |
|---------------|---|-------------|
| Figure 2-1 | Electrical Usage Display System - Patent 4106095 | 23 |
| Figure 2-2 | Apparatus for monitoring and controlling power consumption | 24 |
| Figure 2-3 | Plug G and Plug C | 26 |
| Figure 2-4 | Type-G plug wire distribution | 26 |
| Figure 2-5 | Current capacity status | 27 |
| Figure 2-6 | Relation between 3 type of power component | 29 |
| Figure 2-7 | Voltage to current phase shift | 30 |
| Figure 2-8 | Current measurement using a shunt resistor and a differential amplifier | 33 |
| Figure 2-9 | Current Transformer | 34 |
| Figure 2-10 | Open loop Hall Effect Sensor | 35 |
| Figure 2-11 | Closed loop Hall Effect Current Sensor | 36 |
| Figure 2-12 | The Concept of rectifier 1 | 39 |
| Figure 2-13 | The concept of rectifier 2 | 40 |
| Figure 2-14 | Rectifier smoothing circuit | 41 |
| Figure 2-15 | P4400 Kill A Watt | 42 |
| Figure 2-16 | Brennenstuhl PM230 Electricity Meter | 43 |
| Figure 2-17 | Watts up .Net meter | 44 |

| | |
|--|-----|
| Figure 2-18 TED 5004-C | 46 |
| Figure 2-19 General ideal how TED 5004-C work | 46 |
| Figure 2-20 Current Transducer (LTS-25-NP) | 47 |
| Figure 2-21 Mode of operating | 48 |
| Figure 2-22 Vout vs Ip | 48 |
| Figure 2-23 Current Transformer (MX3B-30/5A) | 49 |
| Figure 2-24 PIC 16F877A | 50 |
| Figure 2-25 LM7805 | 51 |
| Figure 2-26 LM317 | 52 |
| Figure 2-27 KBP3005G Single Phase Silicon Bridge Rectifier | 53 |
| Figure 2-28 LM 555 Timer | 53 |
| Figure 2-29 Operational amplifier (UA741) | 54 |
| Figure 2-30 16x2 LCD Display | 55 |
| Figure 2-31 NI Ultiboard 10 | 55 |
| Figure 2-32 NI Multisim 10 | 56 |
| Figure 2-33 Proteus VSM | 57 |
| Figure 2-34 MPLAB IDE interface | 58 |
| Figure 2-35 CSS compiler | 59 |
| Figure 3-1 Project Gantt Chart | 101 |
| Figure 3-2 Frist Prototype System Overview | 60 |
| Figure3-3 First prototype current sensor | 61 |
| Figure 3-4 PCB design is created for testing purpose | 62 |
| Figure 3-5 Schematic of Voltage regulator module | 63 |
| Figure 3-6 Control Unit | 64 |
| Figure 3-7 First schematic | 65 |

| | |
|--|-------------------------------------|
| Figure 3-8 Second prototype system overview | 66 |
| Figure 3-9 Current sensor with bridge rectifier design | 67 |
| Figure 3-10 Voltage inverter | 68 |
| Figure 3-11 Third prototype system overview | 69 |
| Figure 3-12 PCB design for control unit | 70 |
| Figure 3-13 Flow chart of the software design | 71 |
| Figure 3-14 Sample Sub Function in the CSS header library | Error! Bookmark not defined. |
| Figure 4-1 KillaWatt meter | 77 |
| Figure 4-2 Primary turn of 2 circuit configuration | 78 |
| Figure 4-3 Current transducer testing 1 | 78 |
| Figure: 4-4 PCB after sparking burn | 79 |
| Figure 4-5 Current transducer testing 2 | 80 |
| Figure4-6 Current transformer testing | 81 |
| Figure 4-7 Output waveform for current transformer | 83 |
| Figure 4-8 Design of inverting amplifier | 83 |
| Figure 4-9 Instrument used in testing op-amp amplifier | 84 |
| Figure 4-10 resultant amplified output with DC voltage generator | 85 |
| Figure 4-11 op-amp amplifier with $\pm 9V$ voltage supply | 86 |
| Figure 4-12 Bridge rectifier testing | 87 |
| Figure: 4-13 P-N junction characteristic | 88 |
| Figure 4-14 rectifier output smoothing circuit | 88 |
| Figure: 4-15 Resultant DC voltage by using 10 μF capacitance | 89 |
| Figure: 4-16 Resultant DC voltage by using 330 μF capacitance | 89 |
| Figure 4-17 Combination modules Testing | 90 |
| Figure 4-18 Output result of combination modules | 90 |

LIST OF SYMBOLS / ABBREVIATIONS

| | |
|-------|------------------------------------|
| LED | Light emitting diode |
| PIC | Peripheral Interface Controller |
| LCD | Liquid Crystal Display |
| PCB | Printed circuit board |
| AC | Alternative current |
| DC | Direct current |
| CFL | Compact fluorescent lamp |
| PF | Power Factor |
| ADC | Analog to digital conversion |
| VAR | Volt-amp-reactive |
| R.M.S | Root means square |
| GND | Ground |
| A | Ampere |
| V | Voltage |
| P | Real Power |
| Q | Reactive power |
| IDE | Integrated development environment |

LIST OF APPENDICES

| APPENDIX | TITLE | PAGE |
|-----------------|---------------|-------------|
| Appendix A | User Manual | 99 |
| Appendix B | Time Schedule | 101 |

CHAPTER 1

INTRODUCTION

1.1 Project Background and Motivation

In last few years, dramatic increases in the price of natural gas and petroleum have resulted in sharp rise in the cost of electricity for consumer use in Malaysia. Energy prices have become a major concern for many consumers. Besides that, consumers also have become increasingly concerned with their impact on the environment. Using electricity wisely can help you get more value for your electricity bill. It also helps to conserve natural resources and reduces the impact energy use has on the environment. Hence, energy efficient appliances have become increasingly popular with consumers, for example, to lower energy usage expenses associated with the appliances, as well as reducing an impact on the environment

The consumption habits of modern consumer lifestyles are causing a huge worldwide waste problem. In a modern home, there are a lot of power consuming devices and appliances, ranging from toasters and kettles to refrigerator, automatic washing machines and water heaters. Each device and appliance consumes electrical power at a different rate and for different lengths of time, with the total power consumption being recorded by an electricity meter (referred to as the domestic meter) installed in the home by the utility supplier.

A major disadvantage of domestic meters is that only display the total power consumption within the home up to the point of inspection. As a consequence the consumer is not able to monitor the power consumption characteristics of a particular

device or appliance or groups of devices of appliances over a prescribed time interval and cannot access historical power usage statistics for a desired period.

Furthermore, domestic meters are not easy to interpret, firstly they have to be read, which for modern digital meters can involve cycling through different displays of measurements until the applicable reading is displayed. This tends not to be a trivial exercise for the average consumer. The cost of consumed energy is normally not made available to the user until a monthly statement is received, this delay can be cause a lot of wastage during periods of high power consumption.

A real time power monitoring system is relates generally to the field of electric energy consumption and more specifically to the power meter having embedded intelligence to decompose occupy current and voltage signals into specific constituent energy consumption for the home appliances in real time. In order to make energy consumers aware of the energy usage of their various appliances, a real time power monitoring system help to gain information regarding energy usage is often provided and alert consumers when it is exceed the current/ power consumption default set by user (with LED or buzzer). It is hoped that this awareness will help energy consumers to avoid energy waste in operating their appliances, this saves electricity and also reduces potential fire hazard. The device is portable it is possible to track down the appliances that contributed and the consumers can take action to conserve, by either installing more energy efficient appliances, or changing their usage behaviours in areas where pricing of electricity varies by time of day, or simply turning loads off when not in use.

1.2 Aims and objectives

The aim of this final year project is to design and develop a real-time power monitoring system for household appliances to address the problem of exceed the power consumption. It should be an accurate and simple to use tool for ordinary consumers to identify the most energy-greedy appliances, by showing the owner the total power drain and giving alert when it exceed the power setting. It provides an

incentive to track down the excessive background power drain. Thus, he/she can work out where energy savings can be made.

The objective of this project is

1. To study, learn and research about the background, history, and application of real time power monitoring system.
2. To study and design an efficient current measurement module and systems.
3. To study and develop a capable hardware/software method to convert analog to digital signal.
4. To study and write programing statement to PIC microcontroller to perform the ADC, power consumption calculation, timer, alert signal, LCD display for the system.
5. To develop a user friendly, portable and efficient real time power monitoring system.

1.3 Project scope and brief description

This final year project is consists of hardware and software development. This energy monitor is a processor based unit to monitor electric energy consumption in a real time basis .At this primitive stage, this project will be developed based on prototype model. Six parts of modules introduced in the hardware implementation. There are voltage regulate modules, current sensor module, op-amp amplifier module, voltage inverter module, Bridge rectifier module and control and display unit. The software development will be making up with program statement of ADC, power consumption calculation, LCD display and alert signal. Overview project concept will be further discussed on chapter 3.

1.4 Problem Statement

In order to develop a user friendly, portable and efficient real time power monitoring system, it required good connection between the main control unit (PIC) and sub modules. The system becomes inadequate if the sub modules does not report accurately and timely information. Studied important parameters for power monitoring, design an efficient current sensor module to provide good data communication with main control unit module (PIC). Good data interpretation from AC to DC with performing analog to digital conversion by main control unit module (PIC). Well organize and design the program statement for circuit control and create an easy operation interface with LCD display.

1.5 Thesis outline

Chapter 1 is the *Introduction* of the entire project. In this chapter, the background, motivations of real time power monitoring system are introduced. Besides, this chapter also includes the Aims and objectives as well as the project major applications , problem statement and briefly introduced the overview of the project.

Chapter 2 is the *Literature Review* of this project. This chapter reviews on the information plus tools that are useful for developing the projects. The review start with studying the background of the power monitoring system , The effectiveness and the Power supply in the Malaysia , I have also do comparison with 3 different kind of current measurement methods and state out the advantages and drawback. Hardware, software needed is introduced. Each of these subtopics offers the fundamental knowledge of the stuffs that used in this project.

Chapter 3 is the *Methodology* used in this project. It focuses on implementation work of hardware and software in developing the system. This chapter mainly explains hardware and software implementation methods, procedures, and steps.

Chapter 4 is the *Result and discussion* for the project. It emphasize on what the resultant experimented data on each sub modules , the problem faced in the hardware and software design , to apply the alternative solution to solved the problem and the step to making improvements.

Chapter 5 is the *Conclusion* of the project. In this chapter, it will conclude the overall of the project and review on the project objectives. It also contains the recommendation and future works that may be applied for this project for further improvements.

CHAPTER 2

LITERATURE REVIEW

2.1 Background of power monitoring system

Measurement and remote display of the amount of energy consumed in a household or commercial establishment has been possible for a considerable time. In 1970's several inventions show an implementation that utilizes connection or attachment to the utility electrical power meter for power monitoring. Example of such invention is: U.S. Pat. No. 4,106,095 to Yarbrough (shown figure1 below) and U.S. Pat. No. 4,207,557 to Gilkeson. Other similar devices that are stand-alone energy meters require permanent installation in line or at the distribution box. Examples of such patent: U.S. Pat. No. 4,080,568 to Funk. These methods or devices are only able to measure the total energy consumed at the premises and cannot readily provide a measurement of the consumption of a specific individual load or group of loads.

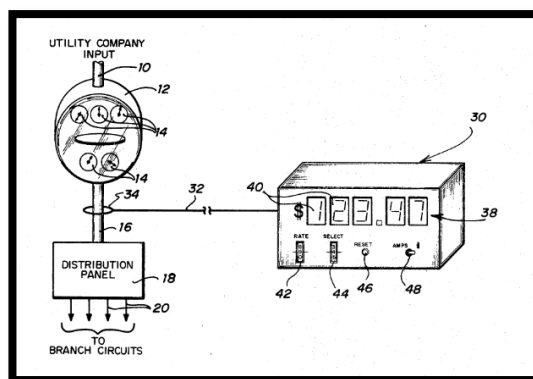

Figure 2-1 Electrical Usage Display System - Patent 4106095

It is also several devices can be measure and record the electrical energy used by an appliance which reveal portable plug-in devices which can measure the energy consumption by individual appliances, which provides a feedback that can allow the user to modify their electrical usage behaviour in order to conserve electricity or to use electricity at low-demand times. Examples of such patents: U.S. Pat. No. 4,253,151 to Bouve, and U.S. Pat. No. 4,901,007 to Sworn. These earlier invention devices are bulky and expensive and it required considerable expertise in their implementation and use. Furthermore, the configurations of these earlier invention devices rely upon a connection being made to the receptacle through suitably sized blade terminals. Connection of the appliance under test to the device relies upon a complete receptacle for the connection of the appliance power cord to the device. Energy flow through the device is thus accomplished with suitably large current connecting, contacting and conducting means necessitating large, bulky and expensive devices.

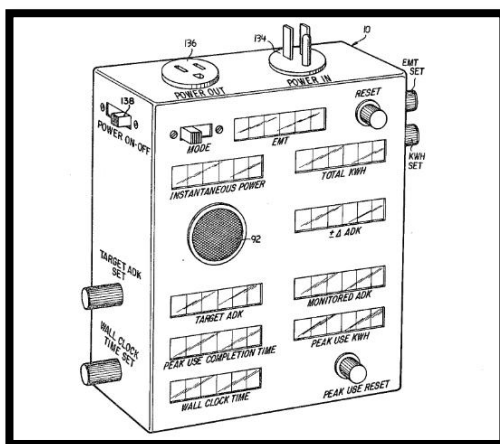

Figure 2-2 Apparatus for monitoring and controlling power consumption

The bulkiness of these prior art devices makes their use problematic as the existing arrangements, since power connection to the appliance must be altered. Additionally, the current contact conducting and measurement means consume considerable energy in their operation. A common measuring means is the use of a resistor through which all current passes to generate a voltage signal. Even if this resistor is only a few milliohms losses are generated at load levels. These prior art devices were not designed to be used continuously in circuit, so these losses are not

substantive in the short term. However, these losses are significant in the long term, therefore this kind of device are not suitable for long-term monitoring.

Comparing with the present invention, the device now can be used continuously without substantially altering, smaller size and portable, simple to use and operational losses through the use of the invention are minimal.

2.2 The Effectiveness of Power Consumption Feedback System.

Metering technologies are as old as the earliest electronic devices, although modern day meters are far more accurate but it still lack of awareness for consumer to understand their usage behaviours. For industrial applications, expensive, high-tech metering solutions are used to minimize costs and to monitor for errors. Most households, however, still use analog electricity meters attached to the outside of their homes. These setups provide almost no opportunity for user feedback, except through monthly billing statements that usually provide little useful data.

Better user feedback has been shown to reduce energy consumption by a significant amount in many cases. Susan Darby, a researcher at Oxford's Environmental Change Institute, has extensively studied energy feedback systems, and she divides them into five main categories: direct feedback, indirect feedback, inadvertent feedback, utility controlled feedback, and energy audits. A real power monitoring device, which is what we have achieved with this project, it is classified as a direct feedback tool. In a survey of over 38 feedback studies over 25 years, direct feedback averaged an energy use savings of 10% and faired the best among all feedback categories (Darby 2001).

Besides that, a study by Ontario Hydro tested direct feedback systems that consisted of computer monitors with simple data interfaces. The experiment lasted for a 60-day period with sample and control groups Oehlerking totaling 100 households. The homes with the feedback installed saved an average of 12.9% over the control groups (Dobson 1992). Since our system also uses LCD to monitors and display feedback data, we could potentially expect similar results.

2.3 Power supply in Malaysia

2.3.1 Plug, main voltage and frequency in Malaysia

The official mains power voltage is AC 230 V .However, the supplied voltage remains at 240 V except in Penang at 230 V. The socket using in Malaysia is mostly in type G (BS1363 Fused 13 A, 5 A and 3A .Type C plugs are very common with audio/video equipment. Plugged into Type G outlets using widely available adapters or forced in by pushing down the shutter. The latter is widely practiced, although hazardous.. Type M sockets are normally used for air conditioning (especially if the air conditioner requires a magnetic starter) and less commonly, washers and clothes dryers.

Since most of the home appliance are using type G socket with fused 13A, our design will design based on the plug and the range of current.

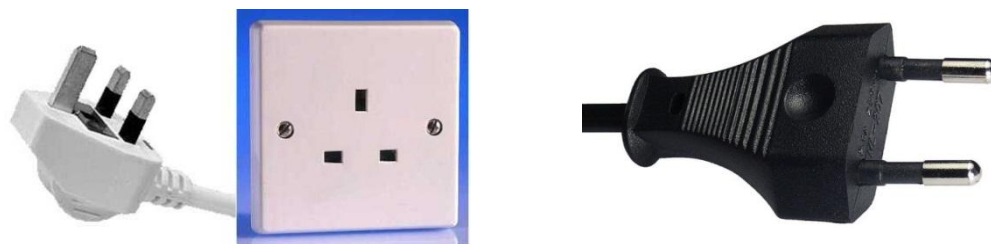

Figure 2-3 Plug G and Plug C

Figure below shown Type-G plug wire distribution, consist of 3 cable namely Live (hot, brown), Neutral (return, blue) and Earth (safety ground, yellow/green).

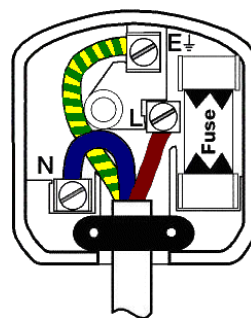

Figure 2-4 Type-G plug wire distribution

2.4 Current Capacity Status

According to the report released on the TNB website, in June 2010, the total available capacity in Peninsular Malaysia stands at 21,052 MW. The highest number of installed plants is gas plants. The total current available capacity of this type of plant is 12,205 MW. Coal plants with 6933 MW of available capacity constitute 33% of the capacity mix. It is then followed by hydro plants which account for 9% of the capacity mix at an available capacity of 1852 MW. As for distillate plants, the current available capacity stands at 62 MW and it contributes to only 0.3% of the mix.

It is apparent that we are highly dependent on fossil fuel sources; approximately 90% of our dependable capacity is either from gas, coal, or distillate. As of now, only hydro is our major non-fossil option.

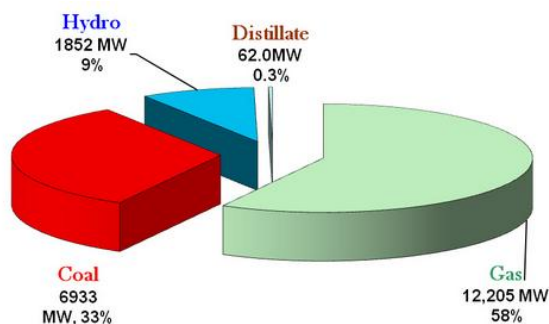

Figure 2-5 Current capacity status

2.5 Steady State Supply Voltage performance in Malaysia

The voltage regulation is highly related to appliance power consumption, since we need to determine the voltage to calculate the power consumption by the device. Therefore, we need to study about the voltage variation for the power supply in Malaysia. The term “voltage regulation” is used to discuss long-term variation in voltage. It does not include short-term variations, which are generally called voltage sags or voltage swells.

According to the report published by TNB with title “Voltage Sag Solution” , In malaysia the voltage regulation requirement are defined in two categories. (Faisal)

1) Range A is for normal condition and the required

| Nominal Voltage | % Variation of nominal voltage |
|-------------------------|---------------------------------------|
| 400V and 230V * | -6% and +10% |
| 6.6kV, 11kV, 22kV, 33kV | ± 5% |
| 132kV and 275kV | -5% and +10% |

Table 2-1 Steady state voltage fluctuation limits under normal condition

2) Range B is for short durations or unusual condition. Under contingency condition , when one or more circuit elements are on outage the power frequency steady-stage voltage at all points in the utility;s distribution system including the points before the consumer metering must be planned to be maintained as follows:

| Nominal Voltage | % Variation of nominal voltage |
|-------------------------|---------------------------------------|
| 400V and 230V | ±10% |
| 6.6kV, 11kV, 22kV, 33kV | ±10% |
| 132kV and 275kV | ±10% |

Table 2-2 Steady state voltage fluctuation limits under contingency condition

As conclusion, we understood that maximum variation power supply in Malaysia is between $\pm 10\%$.

2.6 Important Parameters of Power.

2.6.1 Real, reactive, and apparent power

In AC systems, it supply or consume two kind of power: real power and reactive power. **Real (active) power (P)** and is measured in watts (symbol: W) real power

accomplishes useful work. It represents that actual work done by an electric current or an actual energy consumed by a load to create for example heat, light or motion.

Reactive power (Q) is the power consumed in an AC circuit because of the expansion and collapse of magnetic (inductive) and electrostatic (capacitive) fields. Reactive power is expressed in volt-amperes-reactive (VAR). Unlike true power, reactive power is not useful power because it is stored in the circuit itself. This power is stored by inductors, because they expand and collapse their magnetic field in an attempt to keep current constant, and by capacitors, because they charge and discharge in an attempt to keep voltage constant.

Besides that the total power is called the **apparent power (S)** and measured by volt-amperes or VA.

Figure below shown the relation between 3 components:

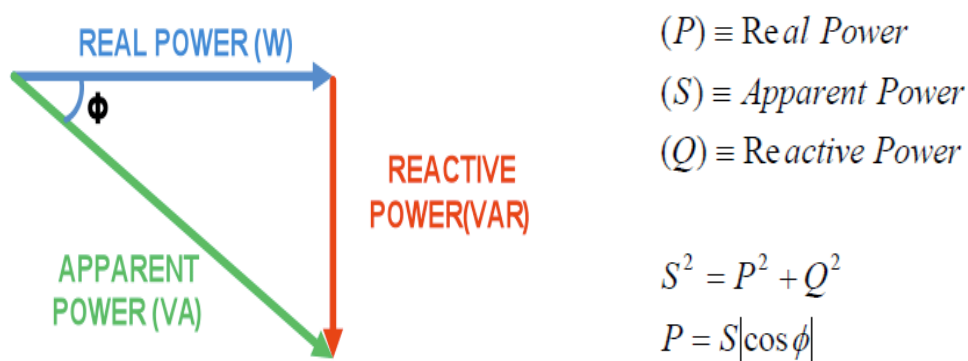

Figure 2-6 Relation between 3 type of power component

In the real time power monitoring system, the load is depending on what appliance that we measured. For the purely resistive circuit for example incandescent light bulb, water heater, the power factor is 1 because the reactive power equals to zero. Here, the power triangle would look like a horizontal line, because the opposite (reactive power) side would have zero length. Therefore real power will be equal as apparent power (Systems, 2009).

For the purely inductive circuit and capacitive circuit, the power factor is zero, because true power equals zero. Here, the power triangle would look like a vertical line, because the adjacent (true power) side would have zero length. Magnetic (inductive) loads, such as motor in the home appliance will cause reactive power occurred, it cause draw more VA than actual real power. The extra component is called a VAR. a VAR (volt-amp-reactive) is basically magnetic power, which causes a phase shift between voltage and current curves shown as figure below (M. Tavakoli Bina, 2011):

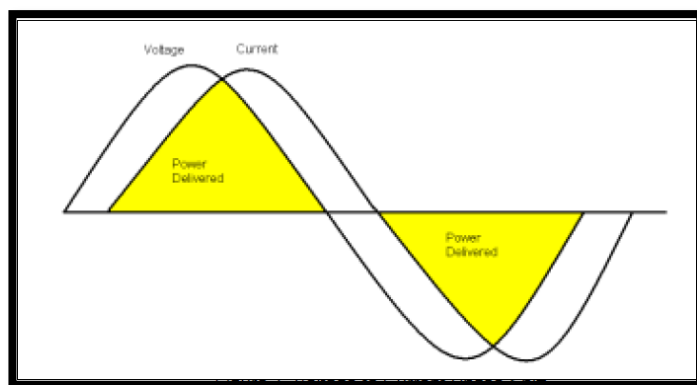

Figure 2-7 Voltage to current phase shift

2.7 Power factor

The **power factor** is important parameters in our design ,the power factor of an AC electric power system is defined as the ratio of the real power flowing to the load to the apparent power. Electrical equipment with non-resistive load has a power factor of less than 1. As an example, we know that CFL (compact fluorescent lamp) light bulbs have a Power factor of between 0.6 ~0.7 depending on maker and wattage. Power factor can be an important aspect to consider in an AC circuit. From the equation (1) and (2) we may know if the power factor less than 1 means (inductive load) that the circuit's wiring has to carry more current than what would be necessary with zero reactance in the circuit to deliver the same amount of (true) power to the resistive load as at this time apparent power will be combination of true power and reactive power.

$$\frac{P}{S} \equiv \text{Power Factor} = |\cos \phi|$$

$$S^2 = P^2 + Q^2 \quad (1)$$

$$P = S|\cos \phi| \quad (2)$$

Power factor will not much affect to end consumer, it is because the electricity meter is based on true power to charge consumer electricity bill, but in our design we are highly concern about this issues. Hence let look into depth with the power factor different in the home appliance.

Electric motors, fluorescent lamps, refrigerator, and consumer electronics (such as televisions and computers) are examples of appliances that have power factors of less than one. This is because they include some type of storage element such as a capacitance or inductance. Since energy efficiency is highly concern, in modern day most of the home appliance is fitted with power factor-corrected power supplies, the average power factor will be maintain within 0.8 to 0.9 to such devices. Table below shown the average power factor in the home appliance tested with a killawatt meter device (Arora, 2010):

| Device | Average power factor |
|--------------------------|----------------------|
| Refrigerator | 0.92 |
| Laptop | 0.86 |
| Answering machine | 0.97 |
| Cell phone charger | 0.52 |
| Game console | 0.90 |
| Compact fluorescent lamp | 0.6 |
| incandescent light bulb | ~1.0 |

| | |
|-------------------------------------|------|
| Water heater | ~1.0 |
| Refrigerator and microwave | 0.80 |
| Laptop , Lamp and hard drive | 0.65 |

Table 2-3 Average power factor based on killawatt meter (Arora, 2010)

In the project design, monitoring with different load result with different power factor, Due to the limited component available in the market, the device used just only can measure on load current in RMS value (current transducer), therefore it only allow us to monitoring on apparent power but not in real power (The characteristic of the current sensor will be elaborate more on coming chapter). From the table 1.3 we can prove that most of the home appliance power factor near to unity, therefore the apparent power that measured has not significant different compare with monitor the real power consumption in the monitoring system.

2.8 Methods of Measurement current

In able to monitoring power consumption, current measure is important as we know that the power are equal to voltage x current. For the current measurement module, most of the component and parameter analysis have to do with selecting the correct component. In doing so, I have performed extensive literature searches on available technologies that can perform for this task.

Measuring electrical current can be done using several methods. There are three methods that are typically used for measuring current: sense resistors, current transformers Hall effect sensors and. Each has attributes that differentiate them on a cost versus performance scale. General characteristics of different current measurement methods discuss below:

2.8.1 Sense resistor

The most commonly used method for measuring current is to run the current through a known resistor. The voltage drop over this resistor is determined by the current and the resistor value. A low value resistance is placed in the circuit and the voltage across it measured. Select a small resistance does not cause much voltage drop over it, so measuring does not considerably complex measured circuit. The resistance is known as a shunt. Any resistance may be used but for large currents and precise results special shunt resistor are available.

General characteristics:

Usually better than 95% accuracy, no galvanic isolation, usually high power dissipation, low cost, typically used for less low currents $< 5A$, works from DC easily up to 100 kHz (or even more)

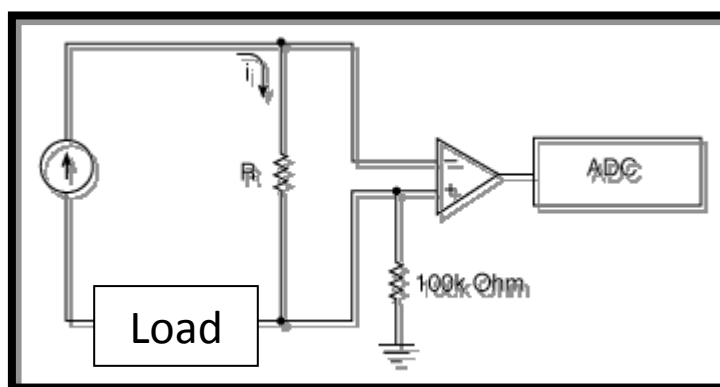

Figure 2-8 Current measurement using a shunt resistor and a differential amplifier

Personal Review:

This is slightly not suitable in this project, it is because the load we deals with are varied and considered high current and high voltage application, thus resistor needed should be high enough to handle the wattage induced , therefore this method is not suggested to be use.

2.8.2 Current Transformer

The current transformer method perform with forming the primary current, a proportional secondary current that can easily be measured or used to control various circuits. The primary winding is connected in series with the source current to be measured, while the secondary winding is normally connected to a meter, relay, device or a burden resistor to develop a low level voltage that is amplified for control purposes. In many high current applications the primary coil is just wire going through the toroid core of the current transformer (equivalent to one turn primary coil). When using just one wire going through the core, that wire can easily made thick enough to be able to handle large currents.

Current transformers are relatively simple to implement and are passive devices that do not require driving circuitry to operate. The primary current (AC) will generate a magnetic field that is coupled into a secondary coil by Faraday's Law. The magnitude of the secondary current is proportional to the number of turns in the coil, which is typically as high as 1000 turns or even more. Output coil outputs give the indication of the current (voltage directly proportional to the current) and provide galvanic isolation. This technique has the advantage that the secondary can be grounded – there is no common mode voltage to deal with. (Pugh, 2009)

General characteristics:

Possible to get quite good accuracy (usually 1-5% error), moderate power dissipation, medium cost, measures easily up to 1000 amperes, works only for AC, usually used for mains frequency AC measurement.

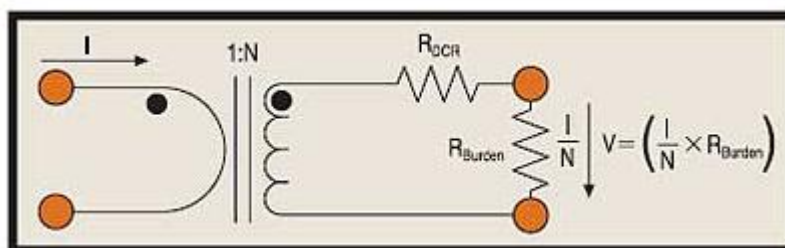

Figure 2-9 Current Transformer

2.8.3 Hall Effect Sensor

The Hall effect uses a semiconductor sensor to convert the magnetic field accompanying the measurement current, into a signal voltage. The output includes both DC and AC components, which makes it attractive. There are two techniques for sensing current using Hall effect devices, open loop and closed loop. The working principle discuss as below:

2.8.4 Open loop Hall Effect Sensor

The configuration of an Open loop sensor is shown in Figure 9. Here the current (I_p) carrying primary conductor passes through the core, and the Hall IC is situated in the air gap of the core. The current through the primary conductor creates a magnetic flux in the core, which is sensed by the Hall IC to produce an output voltage (V_o) proportional to the input current I_p . (Korada)

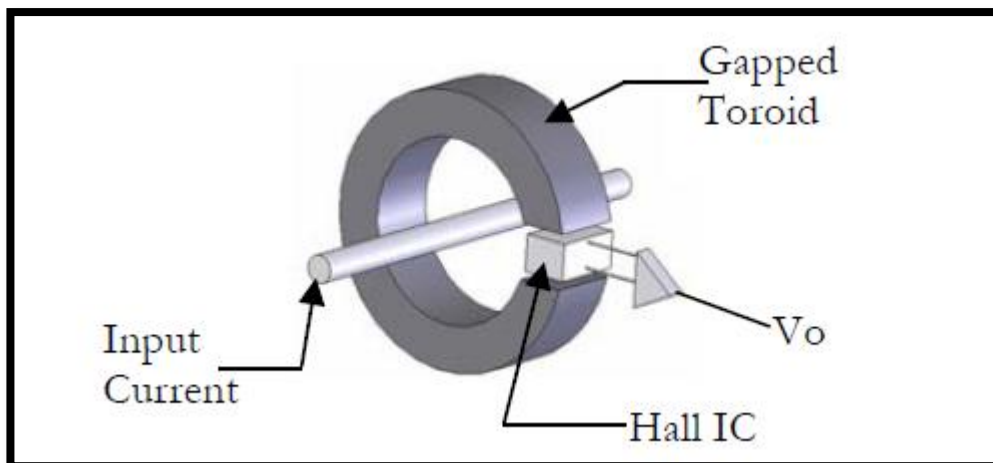

Figure 2-10 Open loop Hall Effect Sensor

2.8.4 Closed loop Hall Effect Sensor

Figure shows the configuration of a closed loop sensor. Here, the output of the Hall IC is amplified and driven through a coil wound around the core. This secondary current, I_s , creates a secondary magnetic field in the core. The magnetic flux from the secondary coil is exactly opposite to that generated by the primary conductor and this result in the cancellation of the magnetic flux in the core. The current through the secondary coil is driven through a resistor to measure a voltage that is proportional to the input current I_p .

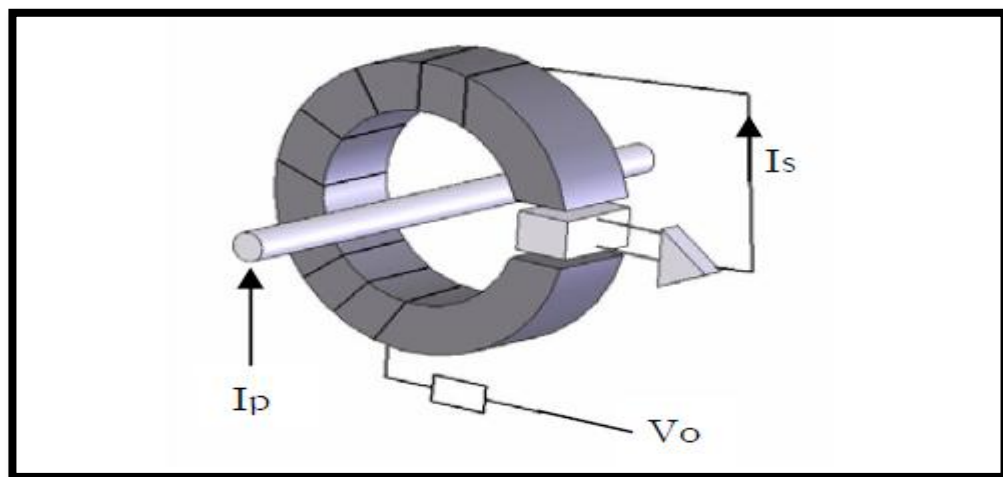

Figure 2-11 Closed loop Hall Effect Current Sensor

General characteristics:

Usually better than 95% accuracy, provides galvanic isolation, moderate to high power consumption, high price, works usually up to 500A, can be made to work from DC to around 150 kHz

2.9 The benefits and drawbacks of the different current sensor technologies

As a summary a table listed along with their benefits and drawbacks for 3 current measurement technologies shown below:

| Sensor | Benefits | Drawback |
|---------------------|---|--|
| Sense resistor | Very low cost, good linearity | Poor high current capability, no galvanic isolation, usually high power dissipation. |
| Current Transformer | High current performance, low power consumption, | Works only for AC, phase shift problem, larger size |
| Hall Effect Sensor | High current performance, good linearity, Optimized response time, No insertion losses, capable AC and DC wide dynamic range, provides galvanic isolation | Higher cost , moderate to high power consumption |

Table 2-4 the benefits and drawbacks of the different current sensor technologies

For the current sensor module, first prototype design was using Hall Effect sensor is determined would best fit the requirements of our project. I decided that **Current Transducer LTS 25-NP** works best for our project for the following reasons: Suitable range current performance, good linearity, high accuracy, easy to operate, and optimized response time. As for more specific parameters in our design a more detailed analysis will be included in the coming section. But unfortunately the device is not working as what we expected at the ideal stage and alternative solution provided. Experimented result will be further discussed on Chapter 4 Result and Discussion.

In the second and third prototype design, the **Current transformer** method was applied, although the accuracy of the measurement method not provide high accuracy due to the reason of losses and deal with lower range of current past through, but it's provide better capacity for current measurement and do not require driving circuitry to operate output coil and it give the indication of the current (voltage directly proportional to the current) and provide galvanic isolation. This

technique has the advantage that the secondary can be grounded therefore more safety compare to the Current transducer which need to feed the current to the circuitry for current measurement.

2.10 Ideal of Analog to digital conversion

Analog-to-digital conversion is an electronic process in which a continuously variable (analog) signal is changed, without altering its essential content, into a multi-level (digital) signal. The input to an analog-to-digital converter (ADC) consists of a voltage that varies among a theoretically infinite number of values but in our project is refer to the DC voltage value. The output of the ADC, in contrast, has defined levels or states.

The resolution of an ADC is usually expressed as the number of bits in its digital output code. For example, an ADC with an n-bit resolution has 2^n possible digital codes which define 2^n step levels. The width of one step is defined as 1 LSB (one least significant bit) and this is often used as the reference unit for other quantities in the specification. $1 \text{ LSB} = V_{\text{REF}} / 2^n$. Besides that selecting the most suitable A/D converter (ADC) for your application is based on more than just the precision or bits. Different architectures are available, each exhibiting advantages and disadvantages in various data-acquisition systems. The required accuracy or precision of the system puts you in a category based on the number of bits required. It is important to always design your system to allow for more bits than initially required: if an application calls for 10 bits of accuracy, choose a 12-bit converter. The achievable accuracy of a converter will always be less than the total number of bits available.

In the project, I would like to perform ADC by using PIC microcontroller which has a 10 bit resolution within 0-5V input which is suitable for the output from the current sensor module. Specification of the PIC will be further discussed in the chapter 2.12 Hardware and component (Morton, The PIC microcontroller: your personal introductory course, 2005).

2.11 The concept of Bridge Rectifier works (conversion between AC to DC)

A bridge rectifier makes use of four diodes in a bridge arrangement to achieve full-wave rectification. This is a widely used configuration, both with individual diodes wired as shown and with single component bridges where the diode bridge is wired internally.

According to the conventional model of current flow originally established by Benjamin Franklin, current is assumed to flow through electrical conductors from the positive to the negative pole. In actuality, free electrons in a conductor nearly always flow from the negative to the positive pole. In the vast majority of applications, however, the actual direction of current flow is irrelevant. Therefore, in the discussion below the conventional model is retained.

In the diagrams below, when the input connected to the left corner of the diamond is positive, and the input connected to the right corner is negative, current flows from the upper supply terminal to the right along the red (positive) path to the output, and returns to the lower supply terminal via the blue (negative) path.

When the input connected to the left corner is negative, and the input connected to the right corner is positive, current flows from the upper supply terminal to the right along the red (positive) path to the output, and returns to the lower supply terminal via the blue (negative) path.

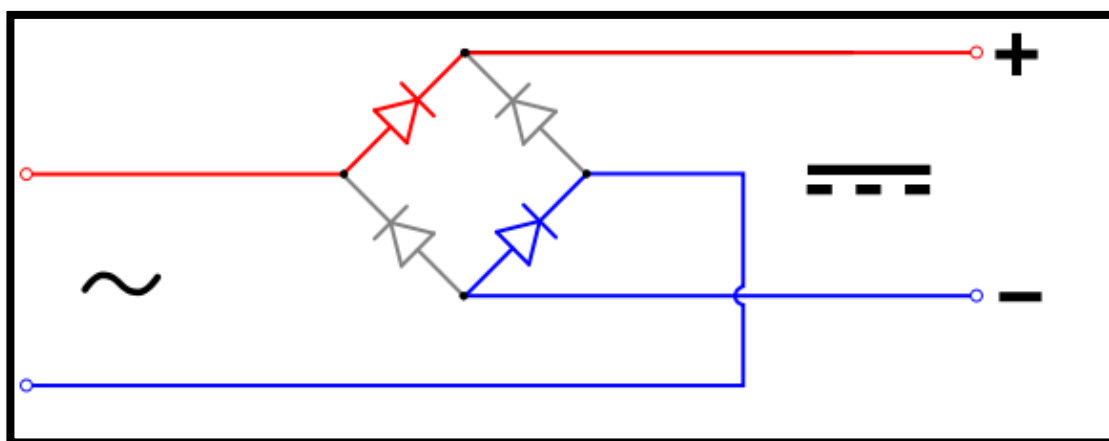

Figure 2-12 The Concept of rectifier 1

When the input connected to the left corner is negative, and the input connected to the right corner is positive, current flows from the upper supply terminal to the right along the red (positive) path to the output, and returns to the lower supply terminal via the blue (negative) path (Nagrath, 2007).

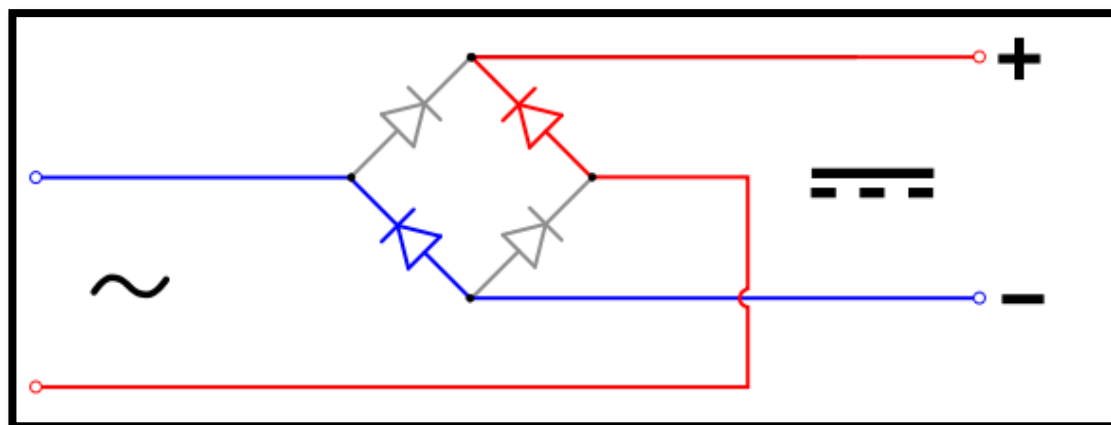

Figure 2-13 The concept of rectifier 2

In each case, the upper right output remains positive and lower right output negative. Since this is true whether the input is AC or DC, this circuit not only produces a DC output from an AC input, it can also provide what is sometimes called "reverse polarity protection" (Nave).

2.11.1 Peak loss of the rectifier

An aspect of most rectification is a loss from the peak input voltage to the peak output voltage, caused by the built-in voltage drop across the diodes (around 0.7 V for ordinary silicon p-n-junction diodes and 0.3 V for Schottky diodes). Half-wave rectification and full-wave rectification using two separate secondaries will have a peak voltage loss of one diode drop. Bridge rectification will have a loss of two diode drops. This may represent significant power loss in very low voltage supplies. In addition, the diodes will not conduct below this voltage, so the circuit is only passing current through for a portion of each half-cycle, causing short segments of zero voltage to appear between each "hump".

2.11.2 Rectifier Output Smoothing

In order to produce steady DC from a rectified AC supply, a smoothing circuit is needed. In its simplest form this can be just a reservoir capacitor or smoothing capacitor, placed at the DC output of the rectifier. There will still remain an amount of AC ripple voltage where the voltage is not completely smoothed.

Sizing of the capacitor represents a trade-off. For a given load, a larger capacitor will reduce ripple but will cost more and will create higher peak currents in the transformer secondary and in the supply feeding it. In extreme cases where many rectifiers are loaded onto a power distribution circuit, it may prove difficult for the power distribution authority to maintain a correctly shaped sinusoidal voltage curve (Vincent, 2009).

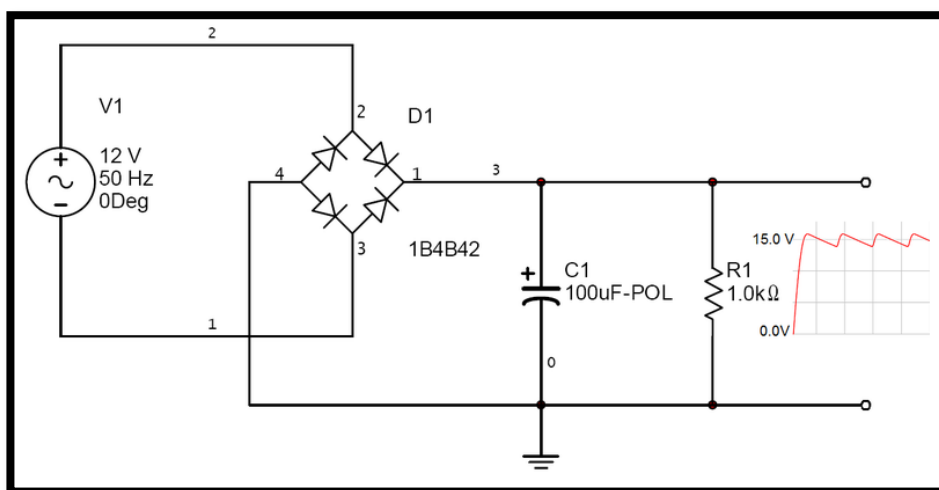

Figure 2-14 Rectifier smoothing circuit

2.12 Ready product in the Market

Researched existing products on the market to see what technologies are being used to monitor electricity usage in the home. There are several products in the market by searching on internet with different production company. Basically they are performing as the similar function such as measure and display the volt, ampere,

frequency, and kilo-watts-hour (KWH). However each of them has different specification to satisfy the standard in different countries used electrical supply. These are some examples of the energy monitor product:

2.12.1 P3 International - P4400 Kill A Watt



Figure 2-15 P4400 Kill A Watt

P3 International P4400, as known as Kill-A-Watt meter is one of the most popular energy monitor device in United States. Operate by simply connect these appliances to the Kill A Watt, and it will assess how efficient they really are. Large LCD display, it count consumption by the Killowatt-hour. User can calculate your electrical expenses by the day, week, month, even an entire year. Also check the quality of the power by monitoring Voltage, Line Frequency, and Power Factor. However the device is not suitable to use in Malaysia, since the operating voltage is in 115~125 VAC but in Malaysia we are in the standard of 240VAC. The price of the device is quite reasonable, it is only (\$ 25 USD) in the market.

Specification of Kill-A-Watt shown below:

| | |
|---------------------------|-------------------------------|
| Model: | P4400 |
| Operating Voltage: | 115 VAC |
| Max Voltage: | 125 VAC |
| Max Current: | 15 A |
| Max Power: | 1875 VA |
| Weight: | 5 oz. |
| Dimensions: | 5 1/8"H x 2 3/8 "W x 1 5/8 "D |

2.12.2 Brennenstuhl PM230 Electricity Meter



Figure 2-16 Brennenstuhl PM230 Electricity Meter

Brennenstuhl PM230 Electricity Meter is manufacturing in German. This device is a lot lighter which only 145g compare with electricity in the market such as the product we discuss previously (p3). It is because the model runs on two tiny LR44 batteries rather than through an internal transformer like the P3-P4400, which draws up to 14W of current whilst plugged in (nearly as much as a low energy spiral light bulb).it perform with the basic function of electricity meter such as measurement of Voltage , current , KWH , frequency. Besides that it device allows the user to program their electricity tariff so the meter automatically calculates how much the appliance is costing. The timer function allows you to set the time and date. Has the facility to enter two-price operation for off-peak (economy-seven) and peak

electricity prices. The batteries contained within the meter means that all the settings inputted will not be lost when you plug it out. The price of the device is slightly higher (\$ 56.8 USD).

The device specification shown below:

| | |
|--------------------------------|-----------------------------|
| Model: | PM230 |
| Operating Voltage: | 2X LR44 battery of 1.5 volt |
| Lowest measured current | 0.2 A |
| Max Current: | 13 A |
| Frequency | 50/60Hz |
| Weight: | 145 g |
| Dimensions: | 13cm x 6cm x 3.67cm |

2.12.3 Watts up? .Net



Figure 2-17 Watts up .Net meter

Wattup .Net, it is the latest product in watt up manufacture with incredible fast response time to measure voltage and current thousands time in a second which enables user to see the surge of the power variation. The special function such as internet enabled and, ideal for remote monitoring, the built-in web server allows data to be accessed via the internet by connect a wireless adapter (for example the Dlink

DWL-G730AP) into the meter's ethernet port, and the meter can be used wirelessly. In addition, the .Net introduces active energy savings. With an internal switching relay, the .Net can turn off power to the end load based on user configurable rules. Besides that, the smart device also calculates the electricity cost in dollars so the user has a better idea how much is the energy consumed. The price of the device is high, it is around (\$245 USD) in the market.

The device specification shown below:

| Model: | Wattup? .Net |
|---------------------------|---------------------|
| Operating Voltage: | 120 VAC |
| Max Voltage: | 250 VAC |
| Max Current: | 15 A |
| Frequency | 50/60Hz |
| Weight: | 1 kg |
| Dimensions: | 18cm x 10cm x 5cm |

2.12.4 TED 5004-C



Figure 2-18 TED 5004-C

TED Model 5004-C is a system that can monitor a few power panel consumption in the same time with Google Power Meter. Model 5004-G comes with all the components necessary to monitor energy usage from four different sources (i.e. two panels and two subpanels to be measured independently or four electrical panels). This package includes one gateway, four MTU/CT sets, and a sleek, wireless display. The data from each MTU is logged/graphed separately, but can also be seen in aggregate as well in the TED Footprints software by connected with a computer. Figure below shown how TED works:



Figure 2-19 General ideal how TED 5004-C work

2.13 Hardware and component

2.13.1 Current Transducer (LTS-25-NP)



Figure 2-20 Current Transducer (LTS-25-NP)

A current transducer is used to describe a device that convert an alternating current (AC) or direct current (DC) signal into a desired voltage range signal that can use in control systems. LTS-25-NP is a kind of closed loop (compensated) multi range current transducer using the Hall Effect. This transducer works in DC, AC, pulsed, mixed, with a galvanic isolation between the primary circuit (high power) and the secondary circuit (electronic circuit). As for the current sensor, Hall Effect sensor works best for our project for the following reasons:

Suitable range current performance:

Allow Primary nominal r.m.s. current up to 25A, provide with 3 mode of primary turns for better accuracy in 25A, 12A and 8A in 50/60 Hz. Allow 2 different working method by measuring current with wire go through the hole provided for high current mode, another method will be feed the input current to the pin provided, with 3 different configuration for better accuracy in the different design range.

| Number of primary turns | Primary nominal r.m.s. current I_{PN} [A] | Nominal output voltage V_{OUT} [V] | Primary resistance R_p [m Ω] | Primary insertion inductance L_p [μ H] | Recommended connections |
|-------------------------|---|--------------------------------------|--|---|---|
| 1 | ± 25 | 2.5 ± 0.625 | 0.18 | 0.013 |  |
| 2 | ± 12 | 2.5 ± 0.600 | 0.81 | 0.05 |  |
| 3 | ± 8 | 2.5 ± 0.600 | 1.62 | 0.12 |  |

Figure 2-21 Mode of operating

Good linearity:

From the data sheet it shown that LTS-25-NP having a good linearity in detecting current with suitable output shown below:

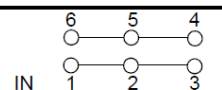
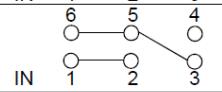
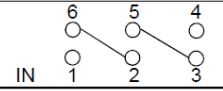
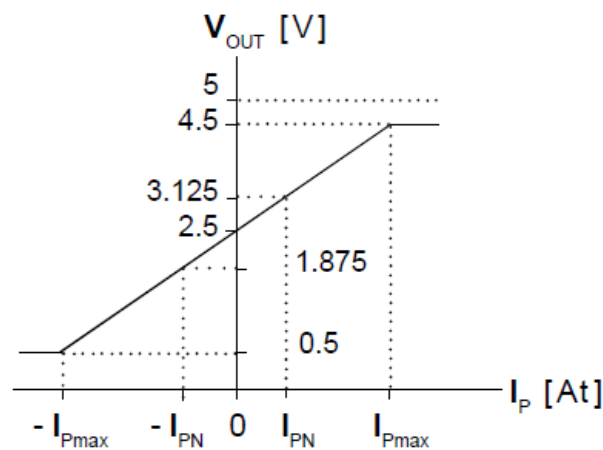

Figure 2-22 Vout vs Ip

High accuracy:

Accuracy @ I_{pn} , $T = 25\text{ }^{\circ}\text{C}$ $\pm 0.2\%$

Accuracy with R_{IM} @ I_{pn} , $T = 25\text{ }^{\circ}\text{C}$ $\pm 0.7\%$

Easy to operate and optimized response time:

Compact design for PCB mounting,

Reaction time @ 10 % of $I_{pn} < 100\text{ ns}$

Response time @ 90 % of $I_{pn} < 400\text{ ns}$

The LTS-25NP current transducer is used in current measurement module for first prototype model of this project to sense the input current and output with desired

voltage to communicate with PIC microchip to perform the ADC and further computation. But the result is not as what we expected, therefore instead of using current transducer, current transformer is used for the second prototype design.

2.13.2 Current Transformer (MX3B-30/5A)



Figure 2-23 Current Transformer (MX3B-30/5A)

A **current transformer (CT)** is used for measurement of electric currents. A current transformer produces a reduced current accurately proportional to the current in the circuit, which can be conveniently connected to measuring and recording instruments. A current transformer also isolates the measuring instruments from what may be very high voltage in the monitored circuit.

In the project Mpex-MX3B current transformer is used as alternative solution once realise current transducer is not working perfectly. MX3B provide constant AC output with provide galvanic isolation which is more safety and provide more measure capacity up to 1000A. There are 2 type of current transformer , Current output or Voltage output , in this case Voltage transformer is used (practical result provided on chapter Result and discussion)

Technical specification:

Dielectric range: 2500Vr.m.s for 1 minute

Voltage: primary rated up to 660V AC

Rated short time current: 2000 Amps for 1 second

Frequency: 50/60Hz

Temperature: -20 to 70 degree celcius

Insulation: class B

2.13.3 Microcontroller (PIC 16F877A)

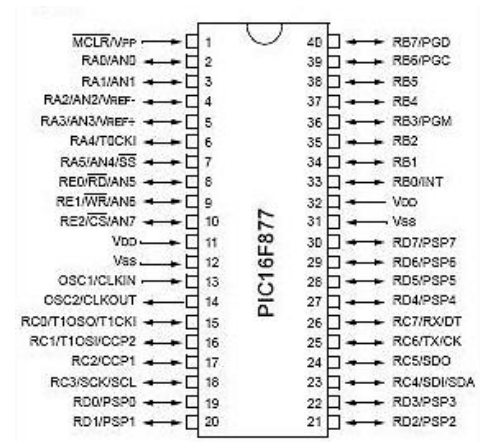

Figure 2-24 PIC 16F877A

40 pins multiple function 8 bits microcontroller PIC 16F877A from microchip consists simple center processing unit (CPU) of 8K x 14 words of Flash program memory, 368 x 8 bytes of Data Memory (RAM) and 256 x 8 bytes of EEPROM data memory with A,B,C,D and E input/output ports provided.

The function provided by this microcontroller is Timer which works as a counter, PWM module which works as controller to increase or decrease the power of any device such as motor of bulb, Synchronous (SSP) and Universal Synchronous Asynchronous Receiver Transmitter (USART/SCI) which are commonly used as the connection to computer terminal through serial port. 8channels 10 bits Analog to Digital Converter (ADC) which used to convert an analogue signal within 0-5V to a binary signal 1 or 0, Comparator provided which used to compare two inputs and output, indicate these input are same or different and etc.

The characteristic of PIC 16F877A microcontroller are:

-Low power, high speed Flash / EEPROM technology.

- Easy to design and reasonable price.
- Wide operating range (2.0V to 5.5V)
- Commercial and industrial operating temperature range

Personal review:

I have decided to use this microcontroller in the project as main control unit, perform with inputs variables, logical processing, and output control. More detail will be discussed in coming chapter.

2.14 Voltage regulator

2.14.1 5V Dc voltage regulator (LM7805)

A voltage regulator is an electrical regulator designed to automatically maintain a constant voltage level. The LM7805 series typically has the ability to drive current up to 1A. The component has three legs: Input leg which can hold up to 36VDC Common leg (GND) and an output leg with the regulator's voltage. For maximum voltage regulation, adding a capacitor in parallel between the common leg and the output is usually recommended. This eliminates any high frequency AC voltage that could otherwise combine with the output voltage. See below circuit diagram which represents a typical use of a voltage regulator.

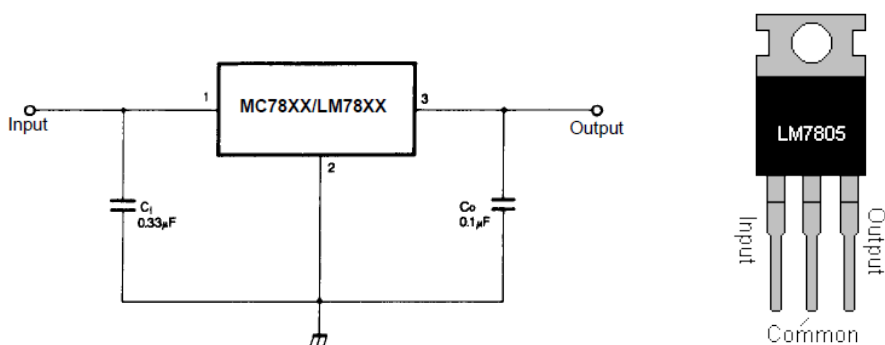

Figure 2-25 LM7805

As a general rule the input voltage should be limited to 2 to 3 volts above the output voltage. The LM78XX series can handle up to 36 volts input, be advised that the power difference between the input and output appears as heat. If the input voltage is

unnecessarily high, the regulator will overheat. Unless sufficient heat dissipation is provided through heat sinking, the regulator will shut down.

2.14.2 LM317 3-Terminal Adjustable Regulator

For an LM317 allow user to adjustable the voltage u wish to be regulated user can calculate the desired LM317 output Voltage by determine the value for R1 to get R2 resistor value for the LM317 with the equation given in datasheet.

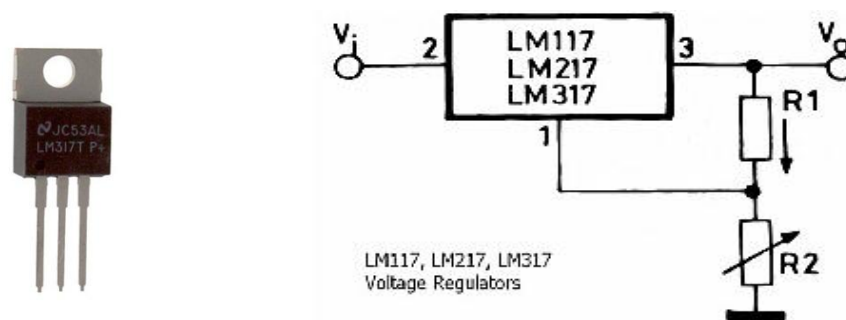

Figure 2-26 LM317

Both of this regulator will be used in voltage regulate module in this project which provide constant voltage from a 9V battery to desired voltage for microcontroler and such device such as relay etc.

2.15 Bridge Rectifier

There are several ways of connecting diodes to make a rectifier to convert AC to DC. The bridge rectifier is one of them and it is available in special packages containing the four diodes required. Bridge rectifiers are rated by their maximum current and maximum reverse voltage. They have four leads or terminals: the two DC outputs are labelled + and -, the two AC inputs are labelled “~”. In the project KBP3005G SINGLE PHASE SILICON BRIDGE RECTIFIER is used.

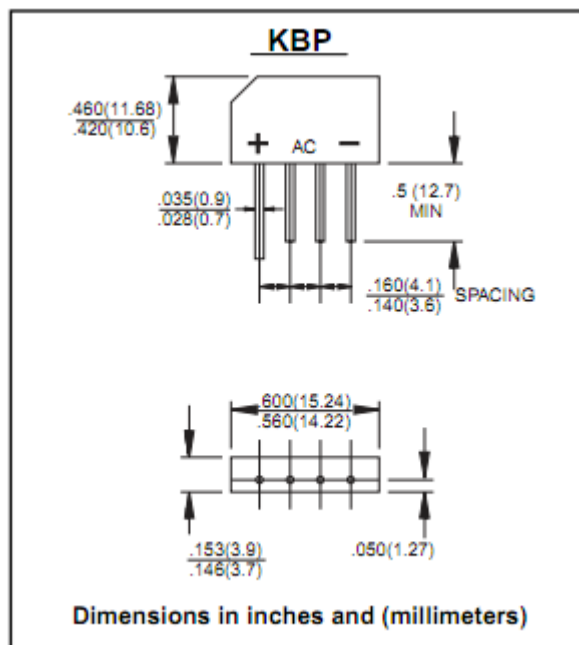

Figure 2-27 KBP3005G Single Phase Silicon Bridge Rectifier

2.16 LM 555 Timer

The LM555 is a highly stable device for generating accurate time delays or oscillation. Additional terminals are provided for triggering or resetting if desired. In the time delay mode of operation, the time is precisely controlled by one external resistor and capacitor. For astable operation as an oscillator, the free running frequency and duty cycle are accurately controlled with two external resistors and one capacitor. The circuit may be triggered and reset on falling waveforms, and the output circuit can source or sink up to 200mA or drive TTL circuits.



Figure 2-28 LM 555 Timer

In this project, LM 555 timer is use for obtain a negative voltage from a positive voltage supply. For operate the opamp for amplification purpose.

2.17 Operational amplifier (UA741)

The UA741 is a high performance monolithic operational amplifier constructed on single silicon Chip. It is intended for a wide range of analog applications.

Such as summing amplifier, Voltage follower, Integrator, Active filter and Function generator

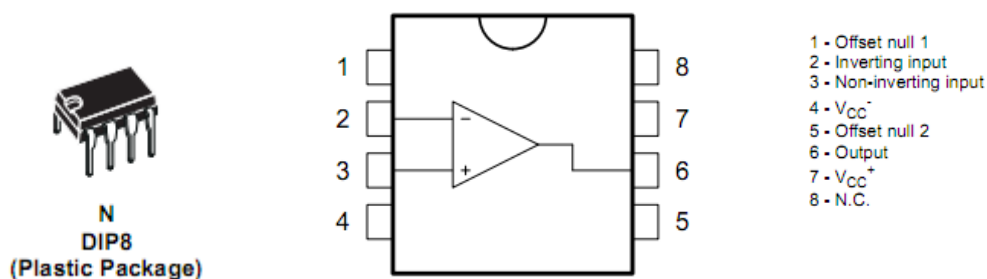

Figure 2-29 Operational amplifier (UA741)

In the project , Opamp UA741 is used to amplifier the insufficient output signal generated from the secondary winding of the current transformer. Amplify to the appropriate amplitude for the purpose to overcome the voltage drop between diode when the AC to DC conversion.

2.18 LCD Display Module

LCD module is one of the most common and useful device for graphical and alphanumerical display from a system. Even for simple display application purposes, LCD has been preferred over other display devices such as seven segment display.

The reason is it is simpler to use compared to older days and it can display 96 ASCII codes.

In this particular part of the project, one 16x2 LCD display is used to display the result of power consumption for the in use home appliance.



| | | | | | | | | | | | | | | | |
|-----|-----|-----|----|-----|----|-----|-----|-----|-----|-----|-----|-----|-----|----|----|
| 1 | 2 | 3 | 4 | 5 | 6 | 7 | 8 | 9 | 0 | 11 | 12 | 13 | 14 | 15 | 16 |
| Vss | Vcc | Vee | RS | R/W | EN | DB0 | DB1 | DB2 | DB3 | DB4 | DB5 | DB6 | DB7 | L+ | L- |

Figure 2-30 16x2 LCD Display

2.19 Software

2.19.1 NI Ultiboard

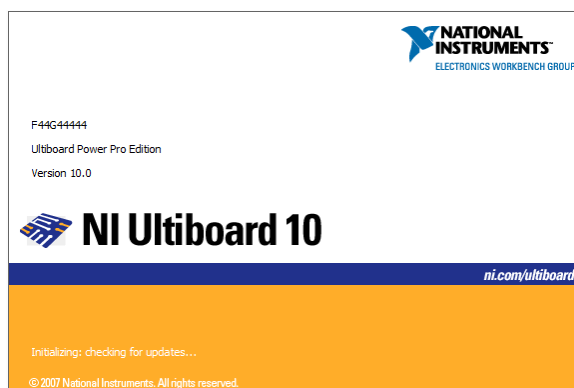

Figure 2-31 NI Ultiboard 10

NI Ultiboard or formerly ULTIboard is an electronic Printed Circuit Board Layout program which is part of a suite of circuit design programs, along with NI Multisim. One of its major features is the Real Time Design Rule Check, a feature that was only offered on expensive work stations in the days when it was introduced. ULTIboard was originally created by a company named Ultimate Technology, which is now a subsidiary of National Instruments. Ultiboard includes a 3D PCB viewing mode, as well as integrated import and export features to the Schematic Capture and Simulation software in the suite, Multisim (National Instruments, 2010). In the project this software is used PCB design purpose.

2.20 NI Multisim

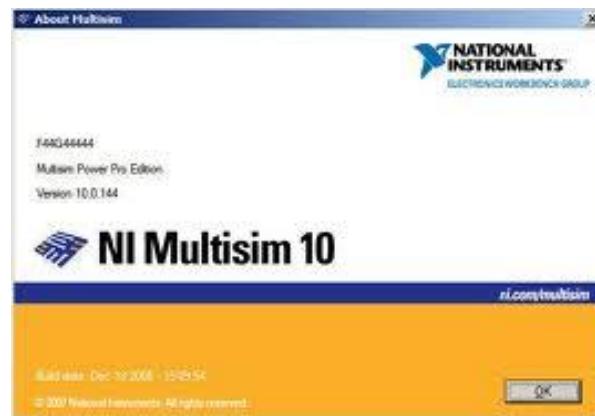

Figure 2-32 NI Multisim 10

NI Multisim (formerly MultiSIM) is an electronic schematic capture and simulation program which is part of a suite of circuit design programs. Multisim is one of the few circuit design programs to employ the original Berkeley SPICE based software simulation. Multisim was originally created by a company named Electronics Workbench, which is now a division of National Instruments. Multisim includes microcontroller simulation (formerly known as MultiMCU), as well as integrated import and export features to the Printed Circuit Board layout software in the suite, Ultiboard (National Instruments, 2010). In this project NI Multisim 10 is used for simulation purpose.

2.22 MPLAB IDE

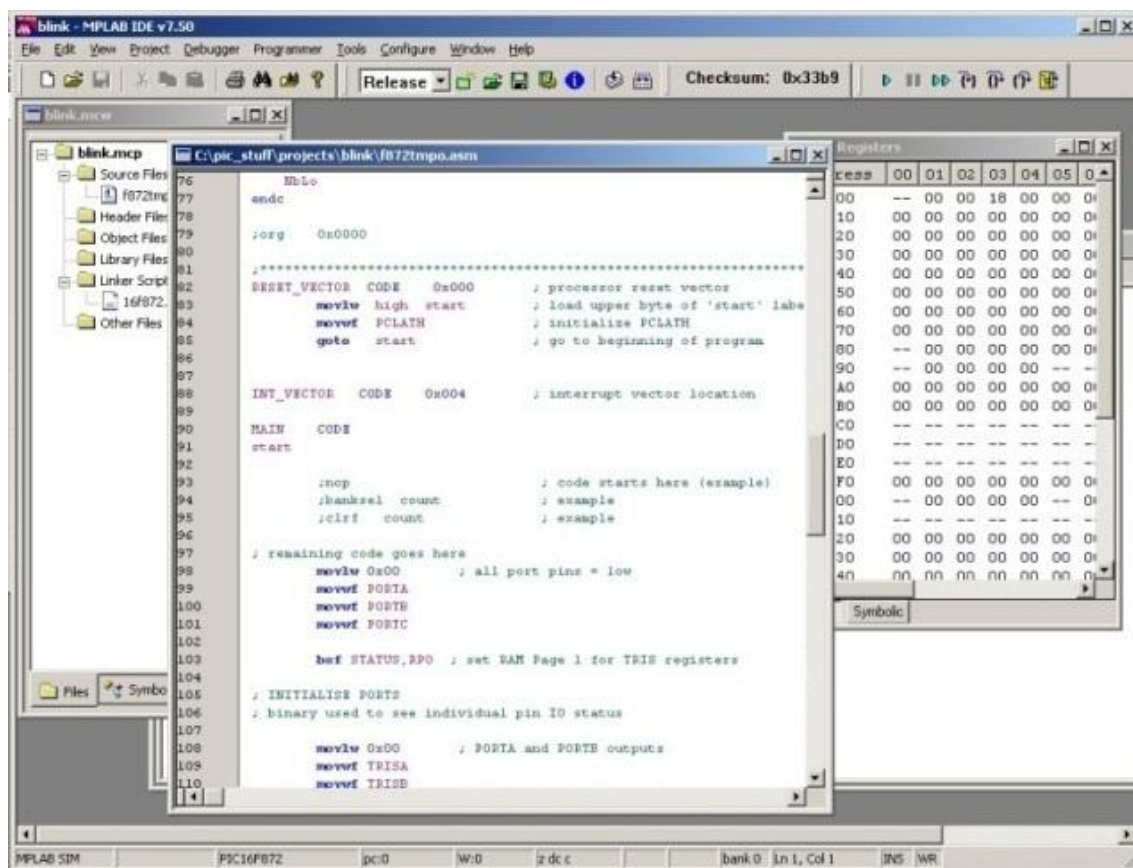

Figure 2-34 MPLAB IDE interface

MPLAB Integrated Development Environment (IDE) is a free, integrated toolset for the development of embedded applications employing Microchip's PIC® and dsPIC® microcontrollers. MPLAB IDE runs as a 32-bit application on MS Windows®, is easy to use and includes a host of free software components for fast application development and super-charged debugging. MPLAB IDE also serves as a single, unified graphical user interface for additional Microchip and third party software and hardware development tools. Moving between tools is a snap, and upgrading from the free software simulator to hardware debug and programming tools is done in a flash because MPLAB IDE has the same user interface for all tools (Microchip, 2010). MPLAB IDE software is the main development used in this project to develop the system instruction.

2.23 CCS C Compiler



Figure 2-35 CSS compiler

Intelligent and highly optimized CCS C compilers contain Standard C operators and Built-in Function libraries that are specific to PIC registers, providing developers with a powerful tool for accessing device hardware features from the C language level. Standard C pre-processors, operators and statements can be combined with hardware specific directives and CCS provided built-in functions and example libraries to quickly develop applications incorporating leading edge technologies such as capacitive touch, wireless and wired communication, motion and motor control and energy management.

In the project CCS built-in function such as ADC , LCD display modules are used to make my programing more easy to be perform and save a lot steps of troubleshooting

CHAPTER 3

METHODOLOGY

3.1 First Prototype System Overview

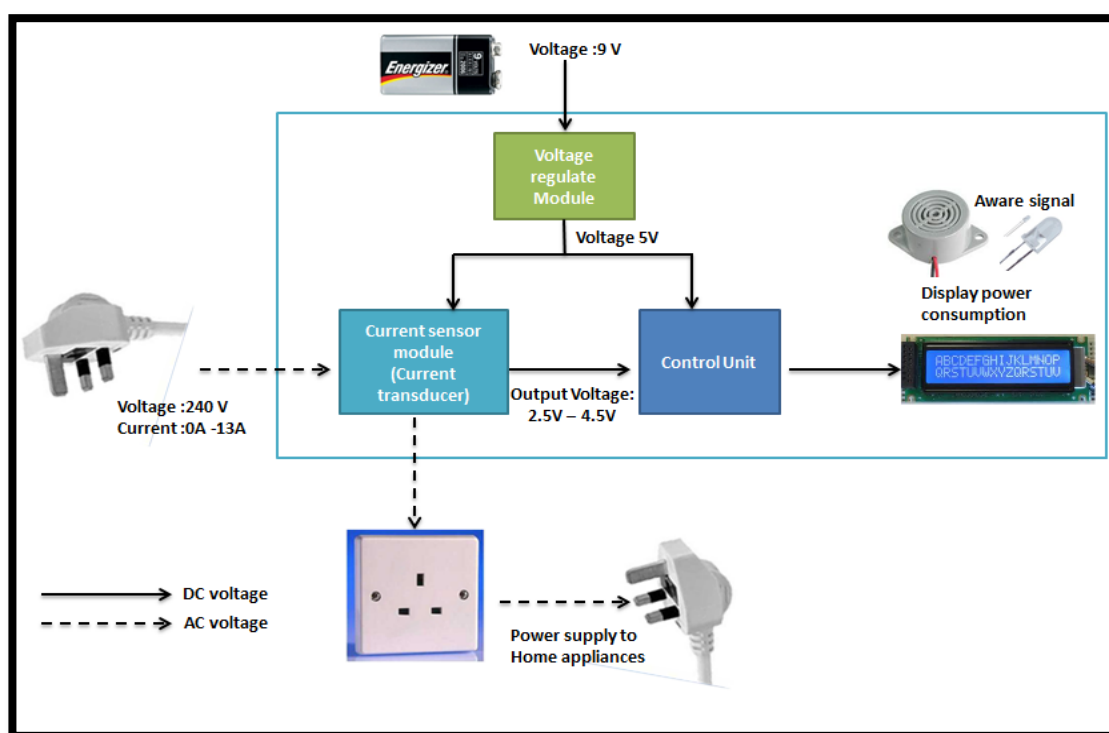

Figure 3-1 Frist Prototype System Overview

Figure above shown the first prototype system overview, there are 3 sub modules: Current sensor module (current transducer), voltage regulate module and control unit. As can be observed from Figure 3-2, the type G plug and outlet is used at the input and output to connect the device to the power outlet and appliance plug, respectively. Inside the 3 core wired, the pronged input splits the live, neutral and earth wires, enabling the current to be measured from the “live” wire only via a current sensor module (either direct feet through or passing by the transducer hole provided). The current measurement (which is output as a DC voltage signal) range

2.5V to 4.5V will be converted to digital signal which perform by control unit (PIC) for analog to digital conversion. Control unit will be performing various functions such as process with power consumption calculation, timer, alert signal and display total power consumption show from the LCD display and alert signal will be given once the current or power exceed the desire pre-set limit. Voltage regulate module is designed to provide a constant voltage level from 9V battery to 5V which is the standard voltage for operating current sensor module and control unit which already stated in datasheet provided.

3.2 First Prototype Hardware implementation

3.2.1 First Prototype Current sensor module

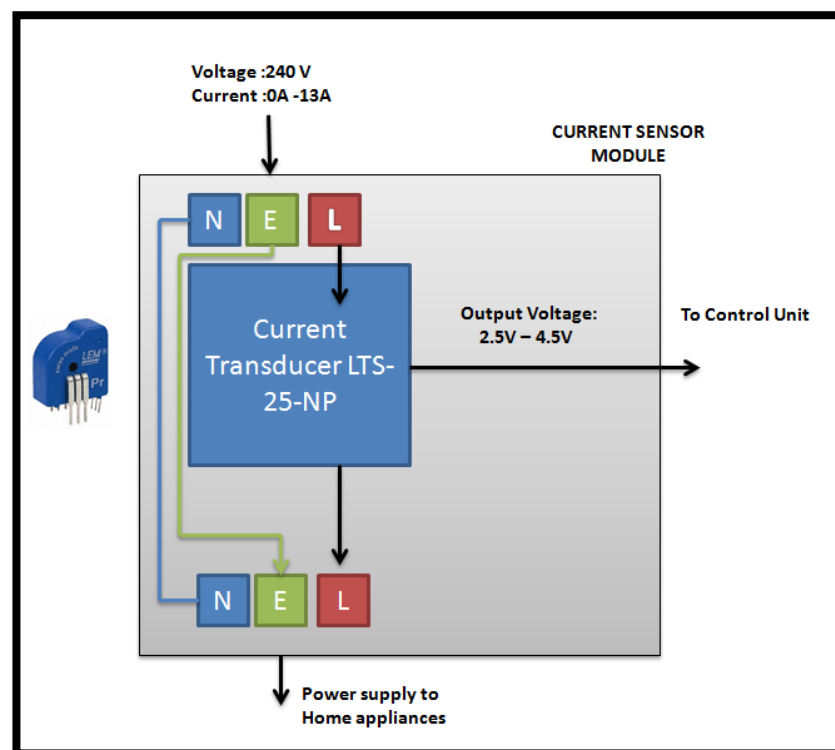

Figure3-2 First prototype current sensor

In the current sensor module, it enabling the current to be measured from the “live” wire only via a current sensor module and neutral and earth are

interconnecting to the outlet to the home appliance plug. Current transducer LTS-25-NP is used provided with 3 modes of primary turns for better accuracy. In this project mode 2 is chosen in the range of 12A which is suitable supply for home appliances. Output with linear voltage depends on detected current (0-12A) with a range of 2.5V-4.5V.

The current sensor outputs a voltage proportional to the root-mean-square (rms) current of the AC circuit. Using a constant voltage of 240 volts, power consumption can be calculated using the rms current. Unfortunately, this value will only be accurate for purely resistive loads. Reactive loads which contain capacitors or inductors will induce a phase lag between the voltage and current waveforms. The apparent power, which is what we are measuring with the current sensor, is actually greater than the real power that is being used by the circuit.

A PCB design is created for testing purpose shown figure below:

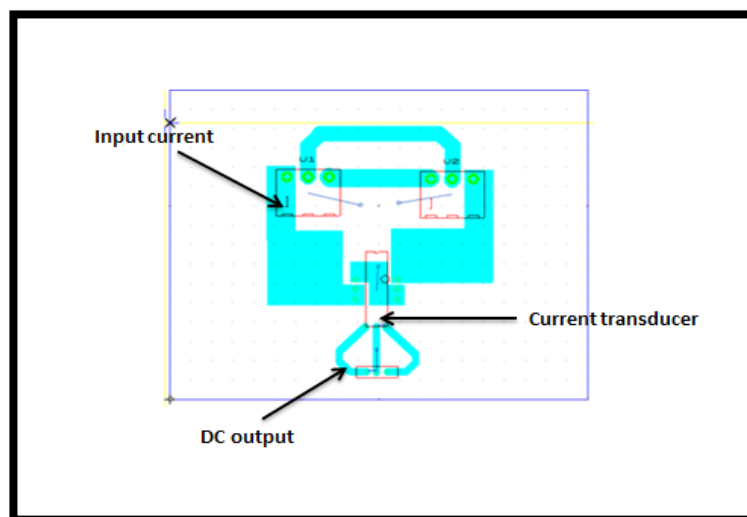

Figure 3-3 PCB design is created for testing purpose

The use of PCB is very important, in this project the operating voltage will be high (AC 240V) and the current is high as well (0-12A). According to the advice from the lab assistants, 1 oz copper PCB is needed to be used for stand the current modules which have the potential to operate in as high as 12A.

Kinsten 1 Oz cooper PCB shown figure bellow is used for the high current measurement design.

3.2.2 Voltage regulate module

Figure shows the circuit of the voltage regulator. In the circuit, LM7805 is used for regulate the input voltage 9V from battery to 5V output voltage. This circuit is design for regulate and stabilize the input voltage to the constant regulated output voltage as the input supply to the PIC which is control unit module and the current sensor module;. The constant input is very important to avoid the PIC microcontroller and the sensor being over voltage and burned. The design of the circuit is able to give about 150mA current, but it can be increased up to 1A when a good cooling is added to the LM7805 regulator chip.

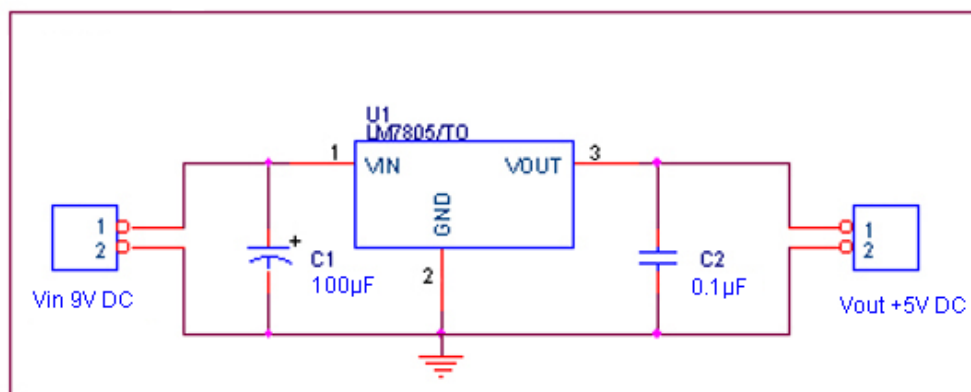

Figure 3-4 Schematic of Voltage regulator module

3.2.3 First prototype Control Unit overview

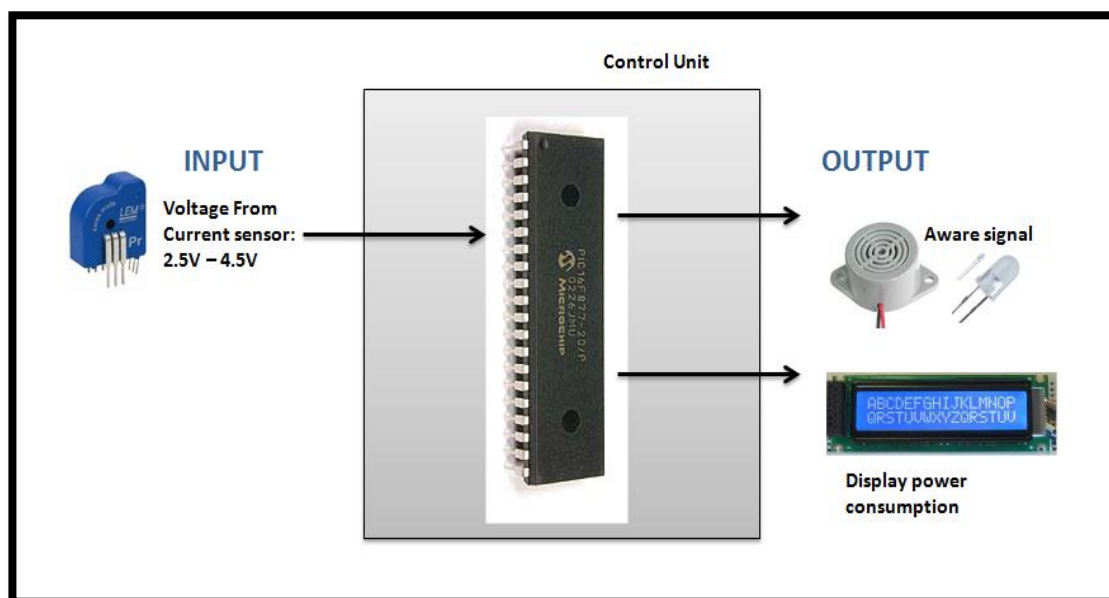

Figure 3-5 Control Unit

Control unit is mainly controlled by PIC and it will process the input from the Current sensor module and further process Analog to digital conversion. Control unit will be performing various functions such as process with power consumption calculation; alert signal and display total power consumption on the LCD display and give an alert signal once exceed the desire pre-set limit.

3.2.4 First prototype schematic

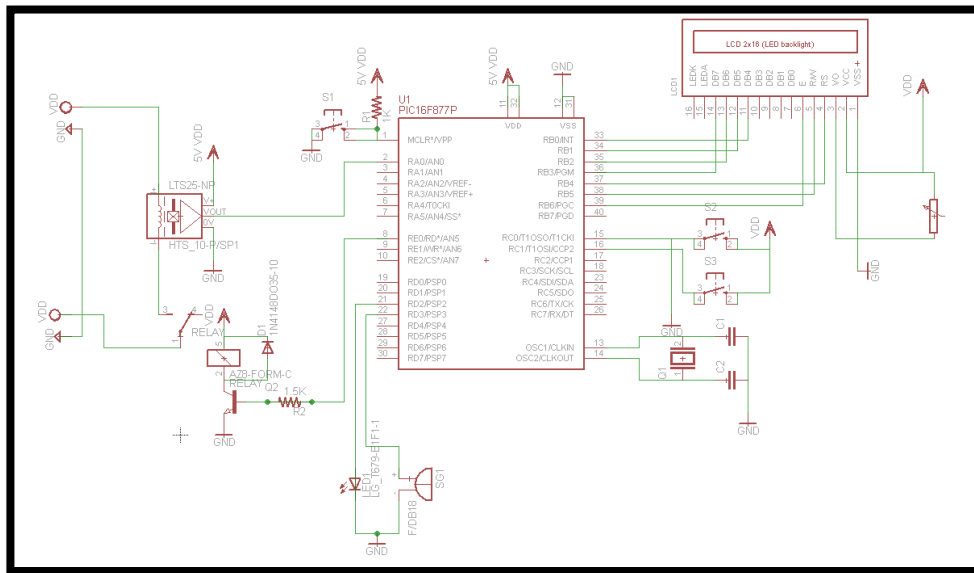

Figure 3-6 First schematic

Figure 3-6 shown the first draft schematic of the project, each component is controlled by each different port in the PIC to make it more systematic and won't be look complicated and confuse to avoid mistake. The Current sensor module are controlled by Port A, Port D is responsible to control of the buzzer and LED light to give alert signal once the current overflow. Port B is mainly use for display LCD reading and Port C is used for button control (perform pre-set limit and start up the device).

3.2.5 First prototype review

The first prototype is **not working** well as what we expected from the first stage of hardware design, unfortunately the current sensor does not working perfectly (output are not proportional to the current measured) as what datasheet stated even though I bought 2 units of same current transducer and run through a few kinds of testing to prof that, therefore I had decided to design my second prototype to overcome the not linear current transducer problem. Practical testing result will be further discussed on the coming Chapter 4 Result and discussion.

3.3 Second prototype Hardware implementation

3.3.1 Second prototype system overview

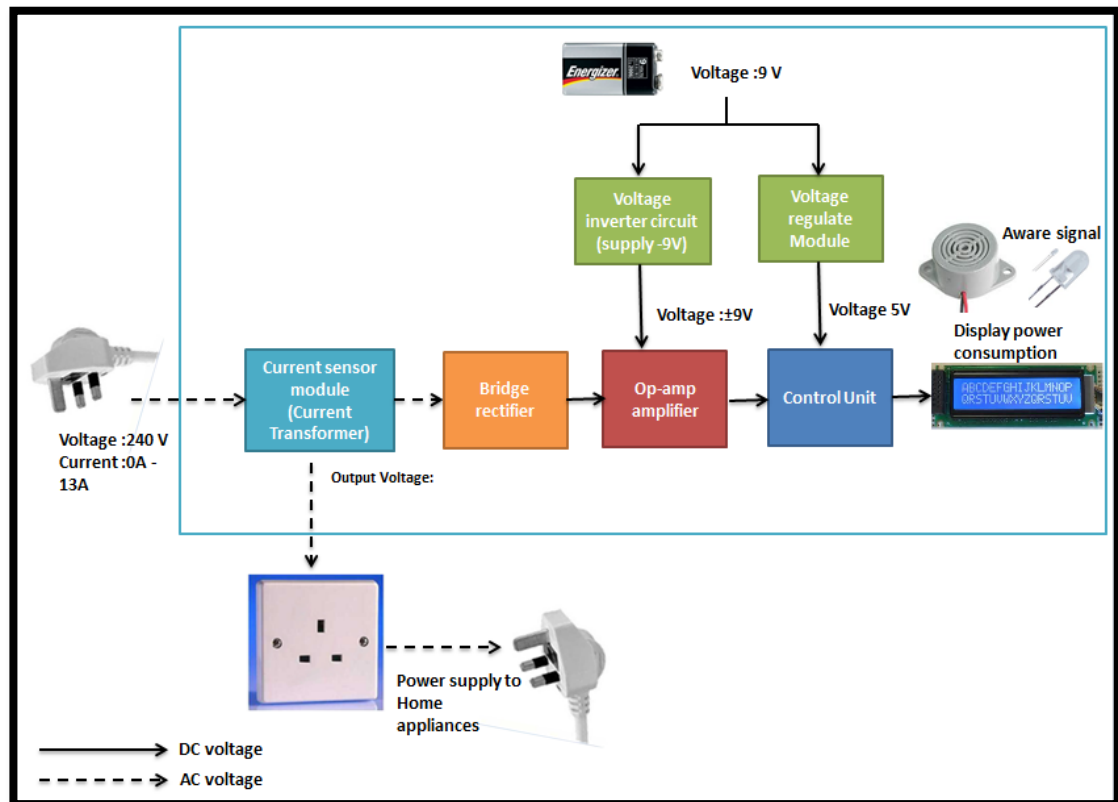

Figure 3-7 Second prototype system overview

Figure above shown the second prototype system overview, there are 6 sub modules: Current sensor module (current transformer), voltage inverter module, voltage regulate module and Bridge rectifier module, Op-amplifier module and control unit. As can be observed from Figure 3-8, the type G plug and outlet is used at the input and output to connect the device to the power outlet and appliance plug, respectively. Inside 3 cores wired, the pronged input splits the live, neutral and earth wires, enabling the current to be measured from the “live” wire only via a current sensor module which is Current transformer in this case. The “live” wire passing through the CT coil for current measurement purpose it is galvanic isolated, the more turns in the primary winding the higher amplitude resultant. The current measurement (which is output as a AC voltage signal) and it will be converted to DC signal which perform by the bridge rectifier modules and furthermore Op-amp is needed for amplified the analog signal to the more larger amplitude, till the sufficient range which suitable for

analog to digital conversion which done by control unit. Control unit will be performing various functions same as the first prototype Voltage regulate module is designed to provide a constant voltage level from 9V battery to 5V which is the standard voltage for operating current sensor module and control unit which same as what first prototype did.

3.3.2 Second prototype Current Sensor with Bridge Rectifier Module

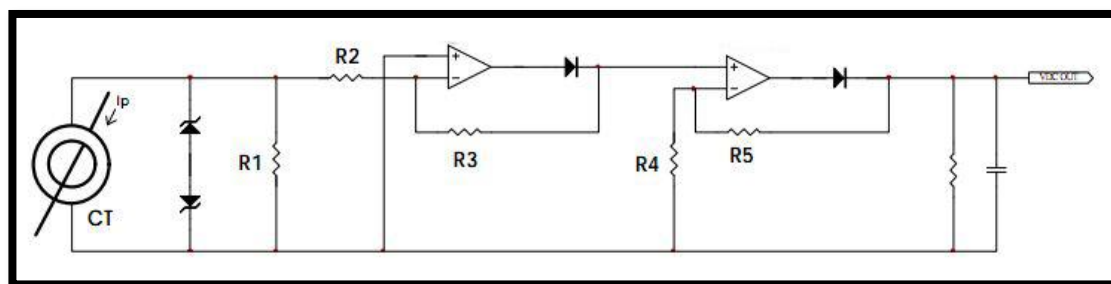

Figure 3-8 Current sensor with bridge rectifier design

In the second prototype design, current sensor module is changed to current transformer instead of using current transducer. By the way, Dc voltage is needed for Control unit for further process because PIC is only accepted with DC voltage but not AC. In order to generate a DC signal from an AC current transformer for input to PIC. The following circuit provides an accurate method for creating this DC signal. The gain of the first stage is always kept at 1 or unity ($R2 = R3$) to guarantee symmetry of the as a buffer .rectified waveform. R2 should be chosen at least 10 times greater than R1 for proper accuracy.

The gain of the second stage is $R5/R4 + 1$. This gain is chosen to get the desired output DC voltage for the designed input voltage.

DC can be generated directly from R1 by applying the AC voltage to a diode bridge. However, the AC voltage required to do AC to DC conversion must be greater than 2 diode voltage drops, or over 2 VAC due to the characteristic of diode and this is what the problem I faced in the second prototype.

3.3.3 Second prototype Voltage inverter

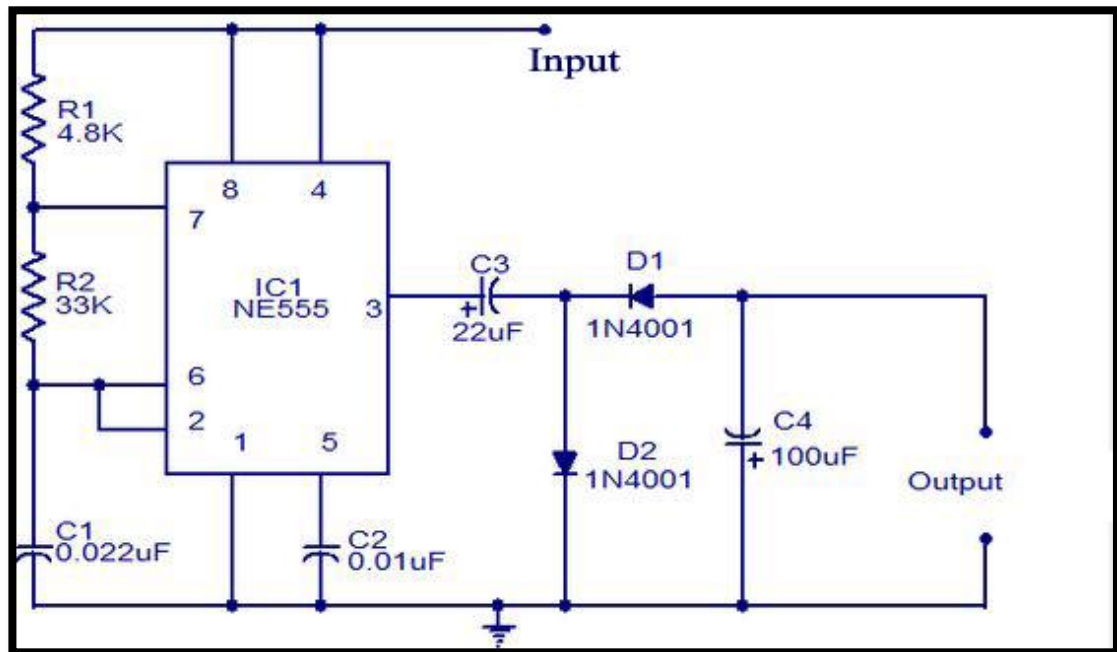

Figure 3-9 Voltage inverter

This circuit diagram shows how to obtain a negative voltage from a positive voltage supply to provide $\pm 9V$ for operating the op-amp in the voltage inverter module. The advantage of this circuit is that, the negative voltage together with the original positive supply can be used to simulate a dual supply. The circuit is based on timer IC NE555. The NE555 is wired as an astable multivibrator operating at around 1 KHz. The square wave output is available at pin no 3 of the IC. During the positive half of the square wave, capacitor C3 charges through diode D2. When the output of IC is at zero the C3 discharges through diode D2 and the capacitor C4 gets charged. As a result of this the voltage at the junction of the anode of D1 and cathode of C4 will be always negative with respect to the ground.

3.3.4 Second prototype review

In the second prototype design, although the current sensor gives a resultant output as proportional to the current measured, But the problem still exist due to the output voltage from CT coil is too low. The AC voltage required doing AC to DC conversion this must be greater than 2 diode voltage drops, or over 2 VAC therefore the design need more higher voltage before it going to the bridge rectifier module,

practical result worked on second prototype will be further more discuss on coming Chapter Result and discussion .

Therefore a little less changes is done in the third prototype design which is amplified the CT coil output before go for AC to DC conversation by bridge rectifier module.

3.4 Third prototype hardware implementation

3.4.1 Third prototype System overview

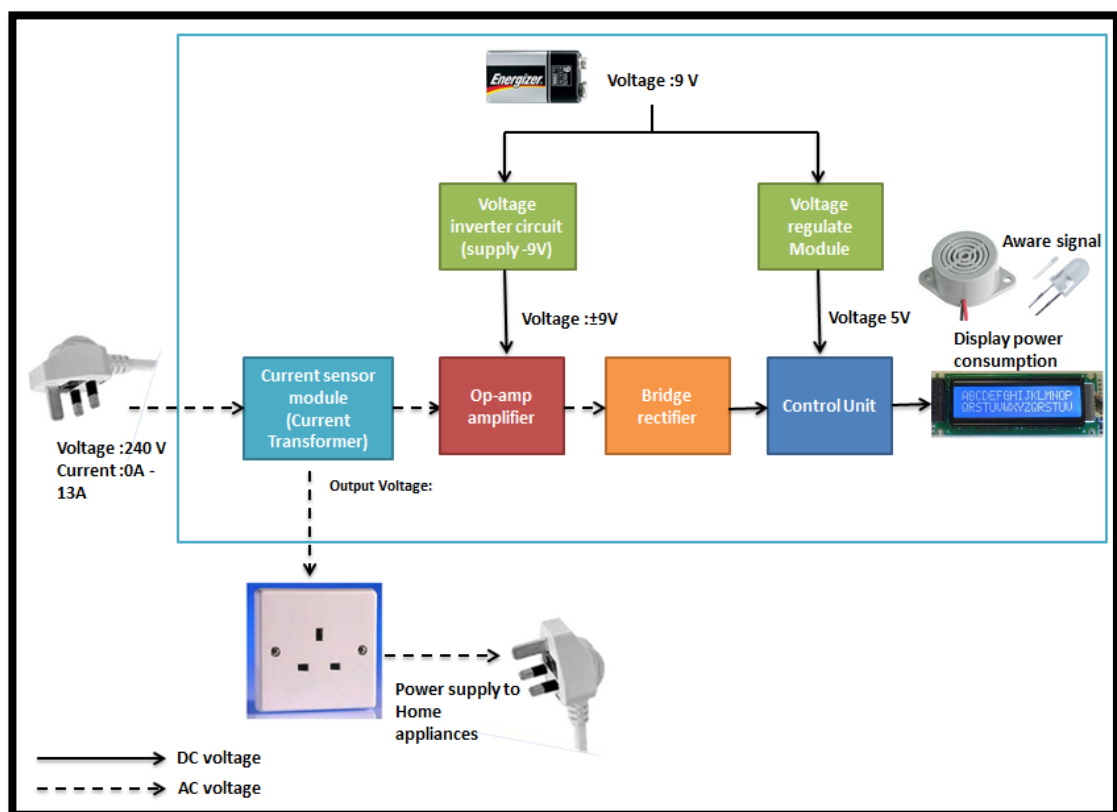

Figure 3-10 Third prototype system overview

In third prototype design, a slightly changes has been made. The op-amp perform as amplifier to amplified the output of CT coil before proceed to Bridge Rectifier for AC to DC conversion, this method works well because the amplified signal which fulfil the characteristic of diode which required doing AC to DC conversion need a amplitude that greater than 2 diode voltage drops. Other than that, all the modules are

similar as what we discuss previously. Practical testing result will be further discuss on coming chapter result and discussion.

3.4.2 Third prototype Control Unit

Control unit is mainly from PIC and it will process the input from the Current sensor module and further process on analog to digital conversion. Control unit will be performing various functions such as power consumption calculation, alert signal and display total power consumption and current on the LCD display and give an alert signal once exceed the desire pre-set limit.

Figure below shown that final PCB design on PIC control unit board, which integrated the +5V voltage regulator module in the same board.

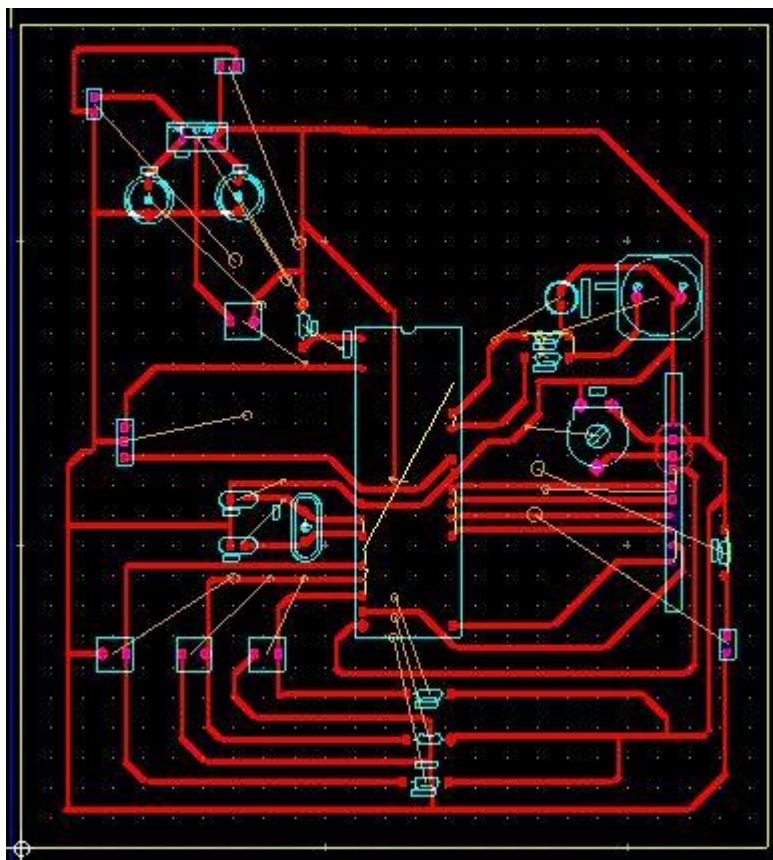

Figure 3-11 PCB design for control unit

3.5 Software implementation

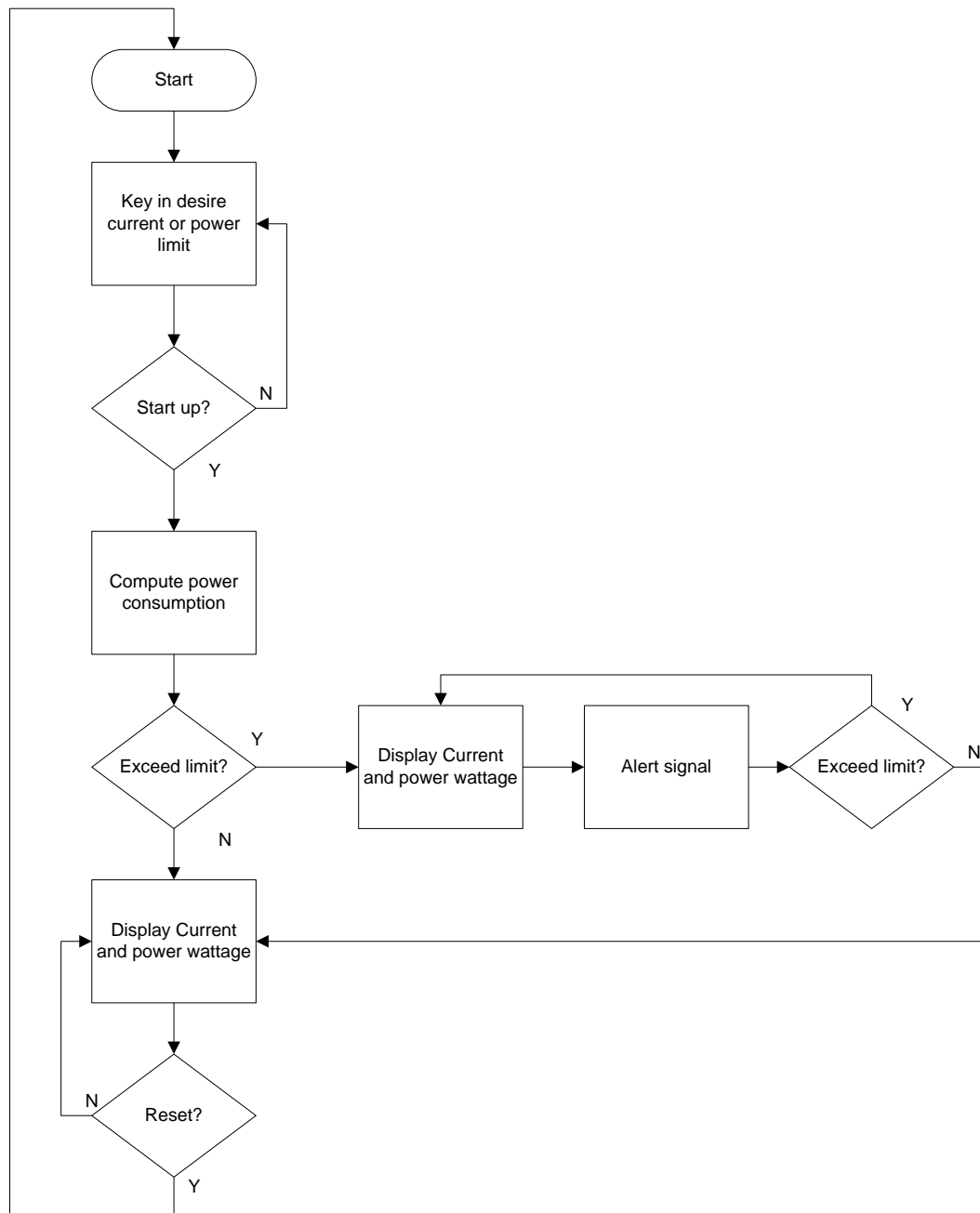

Figure 3-12 Flow chart of the software design

In the software design, C language was used with the CSS compiler which gives a lot of convenient for me to configuring and implementing the software functions with intergraded header libraries. The intergraded header library for PIC 16F877A is provided with various function such as ADC, INTERRUPTS, TIMER, LCD ext. Therefore, ADC and LCD sub functions library was used in my programing coding.

Program source code:

```

#include <16F877A.h>           //Call header
#define ADC=10                //Assign ADC bits
#include <fuses.h>             //Call sub functions
#include <delay.h>             //Assign clock speed

#include <LCDDRIVER.c>        //Call LCD sub function

void main()
{
    float  analin, disvolts, current ,power ,limit=0; //Assign parameters
    int  i ,d ,s;

    lcd_init();              //LCD initialization

    SET_TRIS_C(0xFF);       //Port configuration
    SET_TRIS_A(0xFF);

    SETUP_ADC_PORTS(ALL_ANALOG); // ADC configuration
    setup_adc(ADC_CLOCK_DIV_8);

    lcd_putc("\f");          //Display WELCOME message
    printf(lcd_putc,"WELCOME ENERGY");
    lcd_putc("\n");
    printf(lcd_putc," MONITOR SYSTEM");
    delay_ms(1500);

    lcd_putc("\f");          //Require user key in
    printf(lcd_putc,"Key limit A:%f2.0 A",limit);

    while(1)
    {
        i = input(PIN_C1);    //Assign button
        d = input(PIN_C2);
        s = input(PIN_C3);

        if(s==1)              //before start button press
        {
            if(i==0)
                //debouce
                delay_ms(100);
                //debounce end
                if(i==0)
                {
                    {
                        limit=limit+1 ;
                        lcd_putc("\f");
                        printf(lcd_putc,"Key limit A:%2.0f A",limit);
                    }
                }

            if(d==0)
                delay_ms(100);

            if(d==0)
            {
                {
                    limit=limit-1 ;
                    lcd_putc("\f");
                    printf(lcd_putc,"Key limit A:%2.0f A",limit);
                }
            }
        }
    }
}

```



```

    }
else if ( s == 0)          //After start button press
while(1)
{
    delay_ms(200);
    SET_ADC_CHANNEL(1);      //Set ADC output port as AN1
    delay_ms(140);
    analogin = read_adc();   //Read sampling data

    disvolts = (analogin)/204.6; //formula for power and current calculation

    current = (2.949*disvolts)+0.59;

    power = current*240;

    if ( current <= 0.6)      //IF no current detect
    {

        lcd_putc("\f");
        printf(lcd_putc,"Current:undetected");
        lcd_putc("\n");
        delay_ms(1000);
        OUTPUT_LOW(PIN_B1);
        OUTPUT_LOW(PIN_B2);
        lcd_putc("\f");
        printf(lcd_putc,"Power: undetected");
        delay_ms(1000);

    }

    if ( current >= 0.6 && current >= limit) //IF current more than limit
    {

        lcd_putc("\f");
        printf(lcd_putc,"Current over:%2.0f",limit);
        lcd_putc("\n");
        printf(lcd_putc,"Current now:%2.2f",current);
        delay_ms(100);
        OUTPUT_HIGH(PIN_B1);
        OUTPUT_HIGH(PIN_B2);
        delay_ms(1000);

        lcd_putc("\f");
        printf(lcd_putc,"Power:%4.0f W",power);
        delay_ms(1000);

    }

    if ( current >= 0.6 && current <= limit ) //IF current less than limit
    {
        lcd_putc("\f");
        printf(lcd_putc,"current now:%2.2f",current);
        delay_ms(100);
        OUTPUT_LOW(PIN_B1);
        OUTPUT_LOW(PIN_B2);
        delay_ms(1000);

        lcd_putc("\f");
        printf(lcd_putc,"Power:%4.0f W",power);
        delay_ms(1000);
    }
};

```

```
#include <16F877A.h>           //Call header
#define ADC=10                 //Assign ADC bits
#define fuses HS,NOWDT,NOPROTECT,NOLVP //Call sub functions
#define fuse delay(clock=20000000) //Assign clock speed
```

First of all, the design started with the call function of 16F877A header which provided a lot of useful sub function. In this case ADC and PIC initialisation sub function is used. PIC oscillating speed is set as 20 MHz for high speed process purpose.

```
#include <LCDDRIVER.c>        //Call LCD sub function

void main()
{
    float  analin, disvolts, current ,power ,limit=0; //Assign parameters
    int  i ,d ,s;

    lcd_init();                //LCD initialization

    SET_TRIS_C(0xFF);         //Port configuration
    SET_TRIS_A(0xFF);

    SETUP_ADC_PORTS(ALL_ANALOG); // ADC configuration
    setup_adc(ADC_CLOCK_DIV_8);
```

LCDDRIVE.C is imported as a LCD driver for LCD display purpose. The main program source start with initialisation of each parameter use either type of float or int.

LCD and port initialisation is set as well as the input of the ADC and the sampling rate. In this project, ADC input port is assigned to port A and analog input will be detected by using the (Clock speed / 8) sampling time which mean process per sampled by 0.4 μ sec.

```
lcd_putc("\f");                //Display WELCOME message
printf(lcd_putc,"WELCOME ENERGY");
lcd_putc("\n");
printf(lcd_putc," MONITOR SYSTEM");
delay_ms(1500);

lcd_putc("\f");                //Require user key in
printf(lcd_putc,"Key limit A:%f2.0 A",limit);
```

Initially, Welcome message displayed on LCD and ask for user to enter the preference current limit.

```

while(1)
{
    i = input(PIN_C1);    //Assign button
    d = input(PIN_C2);
    s = input(PIN_C3);

    if(s==1)            //before start button press
    {
        if(i==0)
            //debouce
            delay_ms(100);
            //debounce end
            if(i==0)
            {
                {
                    limit=limit+1 ;
                    lcd_putc("\f");
                    printf(lcd_putc,"Key limit A:%2.0f  A",limit);
                }
            }
        }
    }
}

```

A while loop is built to ensure the program is keep looping on it. Input is assigned with desired pin for user to key in for the current limit and start the program.

“If” condition loop created, it function as increasing the current limit once the button “increase” button is pressed, and continue with If statement of decreasing limit as well.

```

else if ( s == 0)    //After start button press
while(1)
{
    delay_ms(200);
    SET_ADC_CHANNEL(1);    //Set ADC output port as AN1
    delay_ms(140);
    analogin = read_adc();    //Read sampling data

    disvolts = (analogin)/204.6; //formula for power and current calculation
    current = (2.949*disvolts)+0.59;

    power = current*240;

    if ( current <= 0.6)    //IF no current detect
    {
        lcd_putc("\f");
        printf(lcd_putc,"Current:undetected");
        lcd_putc("\n");
        delay_ms(1000);
        OUTPUT_LOW(PIN_B1);
        OUTPUT_LOW(PIN_B2);
        lcd_putc("\f");
        printf(lcd_putc,"Power: undetected");
        delay_ms(1000);
    }
}

```

Another condition loop created. It works once the user pressed the start button, ADC function will be started with getting the reading from the channel 1 which in the pin of AN1. Resultant ADC value will be read and further process with some calculation for getting the power and current reading.

Following by another “If” condition when that is no current detected, LCD output with no current and power detected message.

```

if ( current >= 0.6 && current >= limit) //IF current more than limit
{
    lcd_putc("\f");
    printf(lcd_putc, "Current over:%2.0f", limit);
    lcd_putc("\n");
    printf(lcd_putc, "Current now:%2.2f", current);
    delay_ms(100);
    OUTPUT_HIGH(PIN_B1);
    OUTPUT_HIGH(PIN_B2);
    delay_ms(1000);

    lcd_putc("\f");
    printf(lcd_putc, "Power:%4.0f W", power);
    delay_ms(1000);
}

```

Alert signal and power reading will be shown once the current measurement is exceeding the limit assigned initially by the user. Output Pin B1 and B2 will be set as high which referring to the LED and buzzer alert signal.

Else if the limit does not exceed the initial limit value, only the reading will be shown on LCD until the user press the reset button for restart the system.

```

if ( current >= 0.6 && current <= limit ) //IF current less than limit
{
    lcd_putc("\f");
    printf(lcd_putc, "current now:%2.2f", current);
    delay_ms(100);
    OUTPUT_LOW(PIN_B1);
    OUTPUT_LOW(PIN_B2);
    delay_ms(1000);

    lcd_putc("\f");
    printf(lcd_putc, "Power:%4.0f W", power);
    delay_ms(1000);
}

```

CHAPTER 4

RESULT AND DISCUSSION

4.1 Individual Module Hardware Testing

4.1.1 Current Sensor Module Testing

All the experimented instrument current value is tested on the KillaWatt meter show as figure below as a calibration tool / reference tool.



Figure 4-1 KillaWatt meter

4.1.1.1 Test 1: Current Transducer

The LTS-25-NP Current transducer is tested with the configuration of primary turn 2 which supposes able handle up to 12A current flow measurement. 1 oz copper PCB board is used for the PCB design for high current testing.

| Number of primary turns | Primary nominal r.m.s. current I_{PV} [A] | Nominal output voltage V_{OUT} [V] | Primary resistance R_p [m Ω] | Primary insertion inductance L_p [μ H] | Recommended connections |
|-------------------------|---|--------------------------------------|--|---|-------------------------|
| 1 | ± 25 | 2.5 ± 0.625 | 0.18 | 0.013 | |
| 2 | ± 12 | 2.5 ± 0.600 | 0.81 | 0.05 | |
| 3 | ± 8 | 2.5 ± 0.600 | 1.62 | 0.12 | |

Figure 4-2 Primary turn of 2 circuit configuration

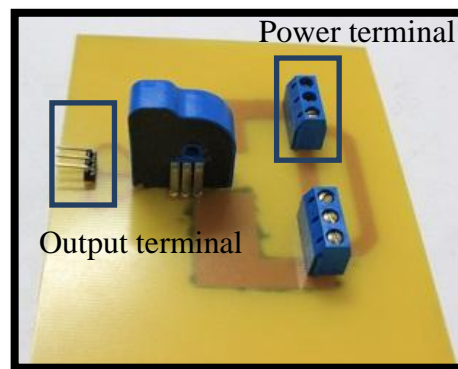

Figure 4-3 Current transducer testing 1

The 3 core wired are connected to the terminal in orderly and “live” wired connect to the current transducer pin 1 for current measurement purpose , output resultant shown below:

Tested Instrument: Hair dryer

| Current | Calculated output (V) | Output (V) |
|---------|-----------------------|------------|
| 3.0 A | 2.6041 | 2.536 |
| 4.2 A | 2.7083 | burned |

Table 4-1 Result of current transducer testing 1

In this case, hair dryer is used in testing purpose, there are 2 adjustment power level provided on the hair dryer, Power one consist of 3.0A current and Power two is consist of 4.2A current flow.

The current transducer provides an output of 2.536V for the measurement of 3.0A which is not accurate as what we expected value of 2.604V provided from the datasheet.

When we go for Power two which consist of 4.2A, the pin of component is burn with spark, therefore no output is shown and I stop the experiment immediately for safety purpose.

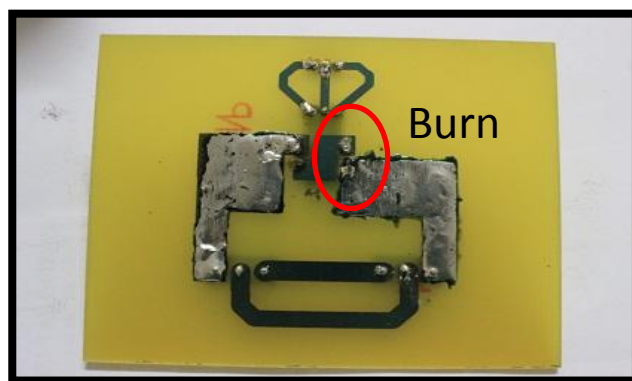

Figure: 4-4 PCB after sparking burn

The reason of spark occurs on board might because of the 6 pins is too near with each other, with the measurement of high current, cause of the electromagnetic flux is high therefore spark may occurred if the pins is not soldier well , it is dangerous with testing on such high current in such a small board provided. Therefore, by following the advice of my supervisor, instead of feeding the current through the current transducer used alternative way for current measuring which is just passing through the wire on the hole provided for safety purpose.

4.1.1.2 Test 2: Current Transducer

2nd method is experimented with passing through the “live” wire through the measurement hole provided on LTS-25-NP shown as figure below:

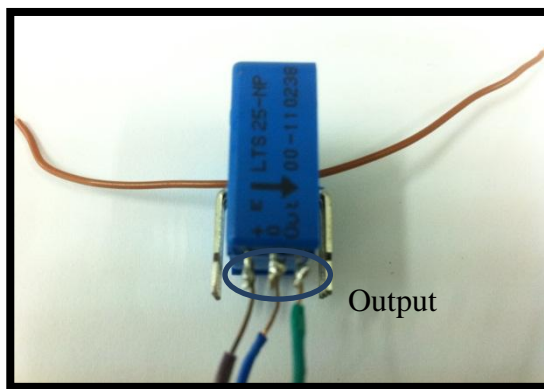

Figure 4-5 Current transducer testing 2

The idea value is tested when no current passing: 2.485 V

Tested instrument: Hair dryer

| Current | Calculated output (V) | Output (V) |
|---------|-----------------------|------------|
| 3.0 A | 2.6041 | 2.536 |
| 4.2 A | 2.7083 | 2.485 |

Tested instrument: Iron

| Current | Calculated output (V) | Output (V) |
|---------|-----------------------|------------|
| 4.937 | 2.757 | 2.485 |

Tested instrument: Induction cooker

| Current | Calculated output (V) | Output (V) |
|---------|-----------------------|------------|
| 0.147A | 2.508 | 2.485 |
| 3.54 A | 2.384 | 2.485 |
| 5.22A | 2.772 | 2.485 |
| 6.80A | 2.854 | 2.485 |
| 7.50A | 2.890 | 2.485 |
| 8.10A | 2.920 | 2.485 |

Table 4-2 Testing on current transducer

From the result above, I presume that the component tested is burn due to the previous testing. Therefore a brand new one are bought and replaced but it takes time for 4 weeks for delivery and it make my schedule delay. Unfortunately a new one

gives same result as what tested previously, no any output provided by using the 2nd method. Since the transducer is not working as what we expected, I decided to have my 2nd prototype design to solve for the problem on current sensor module.

4.1.1.3 Testing the Characteristic of Current transformer

In the project Mpex-MX3B which state as 30:5 current transformer is used as alternative solution once realise current transducer is not working perfectly. Figure below shown on the experiment test on Current transformer induce output by varies of different burden load resistor.

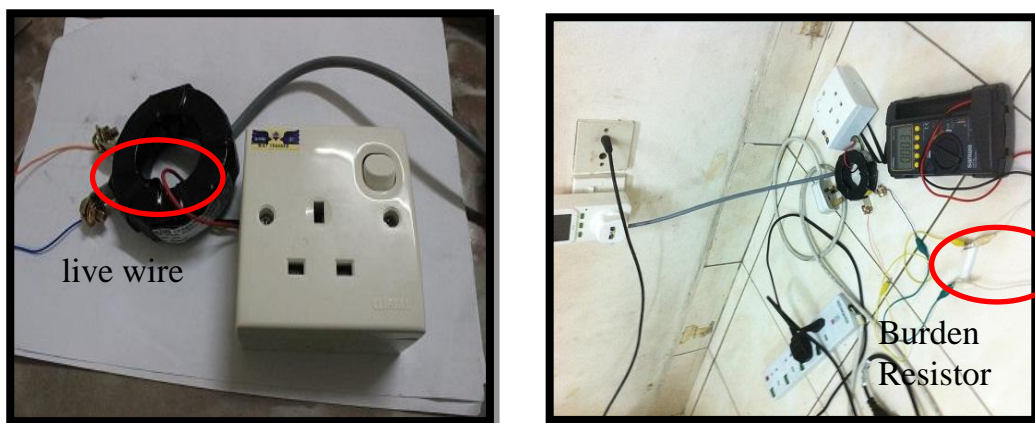
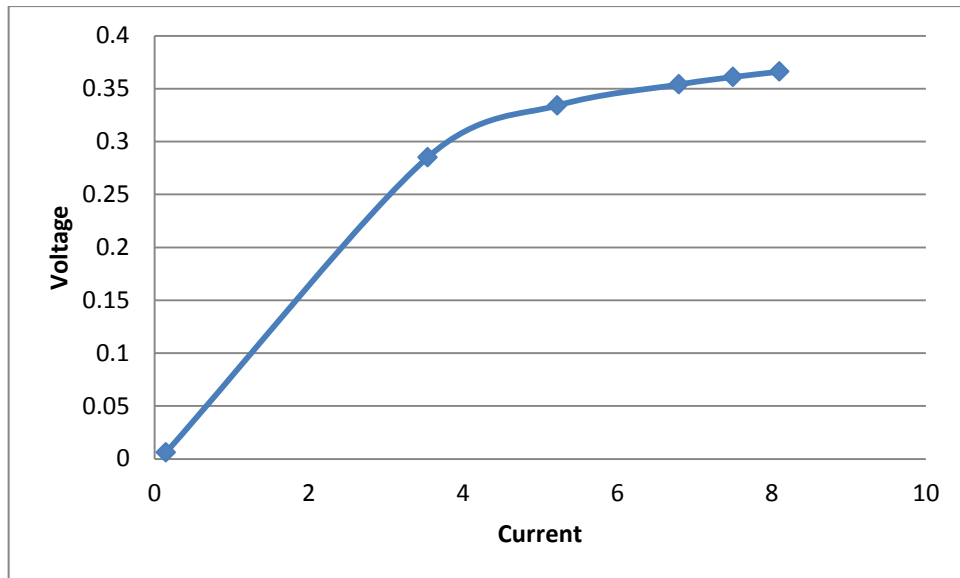

Figure4-6 Current transformer testing

In the experiment different burden load resistors is used and induce voltage (RMS Value) shown below:

| Current | 1 Ω burden output (Vrms) | 10 Ω burden output(Vrms) | 100 Ω burden output(Vrms) | 1 k Ω burden output(Vrms) |
|---------|------------------------------------|------------------------------------|-------------------------------------|-------------------------------------|
| 0.147A | 0.004 V | 0.004 V | 0.004 V | 0.004 V |
| 3.54 A | 0.176 V | 0.174 V | 0.174 V | 0.174 V |
| 5.22A | 0.215 V | 0.215 V | 0.215 V | 0.214 V |
| 6.80A | 0.263 V | 0.262 V | 0.262 V | 0.264 V |
| 7.50A | 0.278 V | 0.279 V | 0.279 V | 0.279 V |
| 8.10A | 0.286 V | 0.290 V | 0.291 V | 0.292 V |

Table 4-3 Result of increasing burden resistance



4-7 IV characteristic of Current transformer Mpex-MX3B

From the result, it can be conclude that that the current transformer is induce voltage but not current. Although the output is not linear but at least it is proportional and stable once the current increasing.

By increasing the primary turn of the current transformer, experimenting result shown below:

| Current | 1 Ω burden output (Vrms) | 10 Ω burden output(Vrms) | 100 Ω burden output(Vrms) | 1 k Ω burden output(Vrms) |
|---------|---------------------------------|---------------------------------|----------------------------------|----------------------------------|
| 0.147A | 0.006 V | 0.006 V | 0.006 V | 0.006 V |
| 3.54 A | 0.232 V | 0.280 V | 0.285 V | 0.285 V |
| 5.22A | 0.292 V | 0.330 V | 0.334 V | 0.333 V |
| 6.80A | 0.317 V | 0.348 V | 0.354 V | 0.354 V |
| 7.50A | 0.325 V | 0.356 V | 0.361 V | 0.360 V |
| 8.10A | 0.326 V | 0.362 V | 0.366 V | 0.365 V |

Table 4-4 Result of increase primary winding

From the result, the induce voltage is obviously increase after the primary turn is increase to 2 instead of 1. We can conclude that the more the turn on primary side,

the more induced voltage which fulfil theoretically. Therefore the induce voltage can be increase either increase the primary turns or amplified by an op-amp amplifier which will be discuss later on.

4.1.1.4 Output of the Current transformer

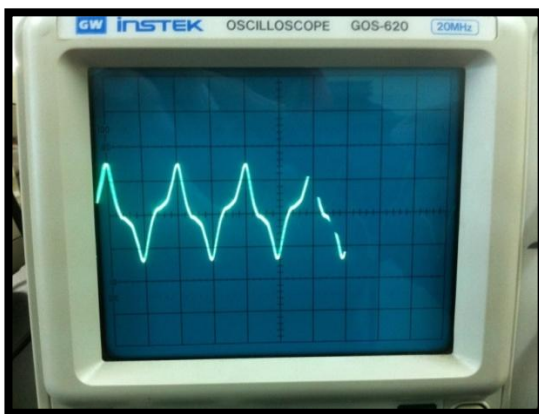

Figure 4-8 Output waveform for current transformer

Figure above shown that the output waveform (AC voltage) from the current transformer, it seen to be not like ordinary AC wave but it still mantaining at the frequency of 50Hz same as the frequency what power supply provided.

4.1.2 Op-amp amplifier module and ± 9 V voltage inverter module testing

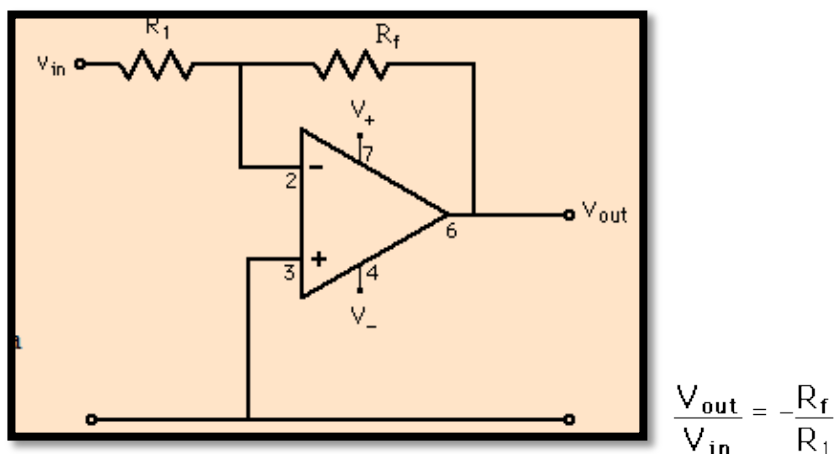

Figure 4-9 Design of inverting amplifier

An inverting amplifier is designed , due to the low output of the current transformer it need to be amplified to overcome the diode voltage drop problem in AC to DC conversion. The ratio of mutiplier is depend on the design of R2 and R1 assigned, result below shown the experimenting on resultant op-amp amplified output. The input is simulated from function generator which provide 50Hz of AC voltage signal and operating voltage $\pm 9V$ from Dc power supply shown as figure shown below.



Figure 4-10 Instrument used in testing op-amp amplifier

4.1.2.1 Testing on Stability Op-amp amplifier module

Test 1

R1= 50 Ω , R2= 1 k Ω , Amplified ratio= 20 times.

| Input voltage (AC peak to peak) | Amplified voltage (AC peak to peak) |
|----------------------------------|--------------------------------------|
| 0.1 Vpp | 1.0 Vpp |
| 0.2 Vpp | 2.2 Vpp |
| 0.3 Vpp | 3.0 Vpp |
| 0.4 Vpp | 4.1 Vpp |

Table 4-5 Amplifier testing 1

The experimented result is not same as what we expected which surpse 20 times amplified theoritically, but resultant with only 10 times, the input is clipping half wave once the op-amp power on, therefore I do recheck back with the op-amp and realize that it is actually a standard requiment input resistance for the min of 100k ohm and maximum 2Mohm. Thus resistance is replaced to fuffill the requirement standard.

Test 2

$R_1 = 100\text{k}\Omega$, $R_2 = 2.2\text{M}\Omega$, Amplified ratio= 22 times.

| Input voltage (AC peak to peak) | Amplified voltage (AC peak to peak) |
|----------------------------------|--------------------------------------|
| 0.1 V _{pp} | 2.0 V _{pp} |
| 0.2 V _{pp} | 4.3 V _{pp} |
| 0.3 V _{pp} | 6.3 V _{pp} |
| 0.4 V _{pp} | 8.8 V _{pp} |

Table 4-6 Amplifier testing 2

Figure below shown the result before and after amplified:

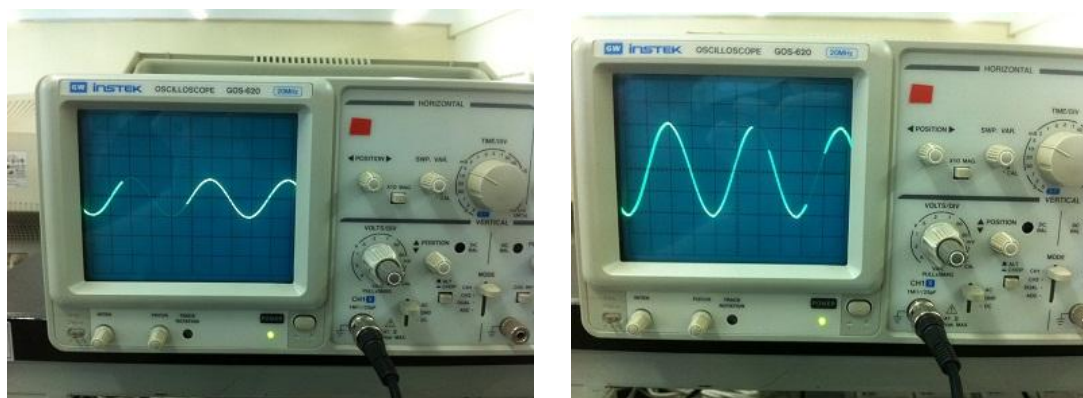

Figure 4-11 resultant amplified output with DC voltage generator

The resultant value is perfectly match as expected value this time ,which amplified around 22times larger than the input analog voltage. The problem solved after follow the input resistance required.

4.1.2.2 Testing the Performance of amplifier with inverter module.

Let further testing on the inverter voltage cuicuit who especially design supply for operate op-amp which consist of $\pm 9\text{V}$. Output voltage recorded and shown as table below:

| Input (From Battery) | Output |
|----------------------|--------|
| 8.94V | -8.12V |

Table 4-7 inverter output

The output voltage (inverted voltage) is not exactly same as the input voltage due to the voltage drop between the components in the circuit design (loading effect). But it is still acceptable and able to operate the op-amp perfectly, but the clipping issue is concern. Therefore output of the inverting amplifier is tested by using the battery and inverter circuit to operate the op-amp, and result shown in table below.

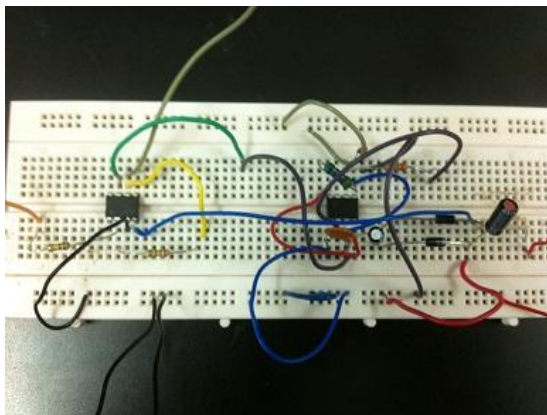

Figure 4-12 op-amp amplifier with $\pm 9V$ voltage supply

| Input voltage (AC) | Amplified voltage(AC) |
|---------------------|--------------------------------|
| 0.1 V _{pp} | 2.0 V _{pp} |
| 0.2 V _{pp} | 4.4 V _{pp} |
| 0.3 V _{pp} | 6.4 V _{pp} |
| 0.4 V _{pp} | 8.0 V _{pp} (clipping) |

Table 4-8 Amplified output with voltage inverter module

The clipping problem occurs once the amplified voltage more than the operating voltage supply (8.12V), this is expected and this is the caution point for my system design. Therefore the amplified circuit should be designed not as larger as this level.

4.1.3 Bridge Rectifier module testing

4.1.3.1 Study of Diode voltage drop in bridge rectifier

Bridge rectifier module is perform AC to DC conversion in the system, Input signal 50 Hz AC signal is generated by the function generator and rectifier is tested parallel with a capacitor and resistor for output smoothing purpose.



Figure 4-13 Bridge rectifier testing

Result below shown that the voltage drop between the diode. Diode exhibits a voltage drop due to its junction built-in voltage and internal resistance. The amount of the voltage drop depends on the semiconductor material and the doping concentrations.

| AC (Peak to peak voltage) | DC voltage (V) |
|---------------------------|----------------|
| 2 Vpp | 0.5 V |
| 3 Vpp | 0.9 V |
| 4 Vpp | 1.2 V |
| 5 Vpp | 1.6 V |
| 6 Vpp | 2.0 V |
| 7 Vpp | 2.4 V |

Table: 4-9 Voltage drop testing between diode

The higher the voltage passing through the diode, the higher the voltage drop due to the increasing of the current it can explain from the characteristics of a P-N junction diode.

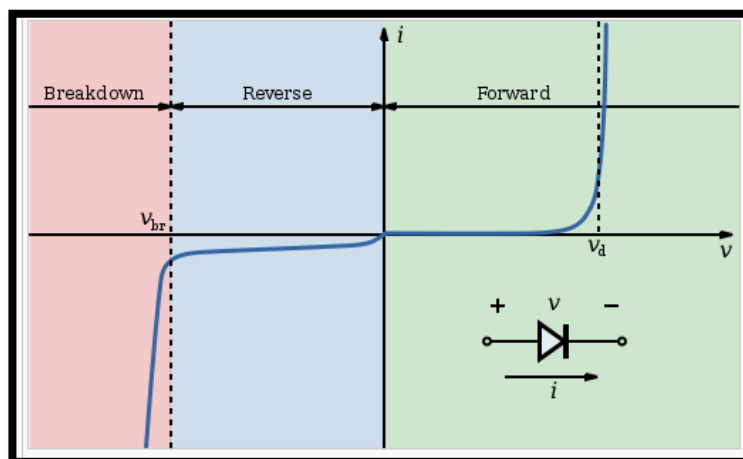

Figure: 4-14 P-N junction characteristic

4.1.3.2 Experiment of Rectifier output smoothing

The design shown below is for the purpose of output smoothing due to the half wave inverting after passing through the rectifier, circuit shown below is constructed to experimenting about what are the effects of changing of capacitance value reflect to the output smoothing effect.

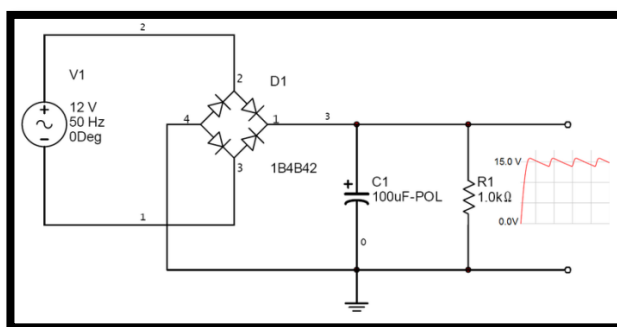

Figure 4-15 rectifier output smoothing circuit

| Capacitance | Smoothing Effect |
|-------------------|------------------|
| 10 μF | Bad |
| 100 μF | Average |
| 330 μF | Good |

Table 4-10 Several of capacitance testing

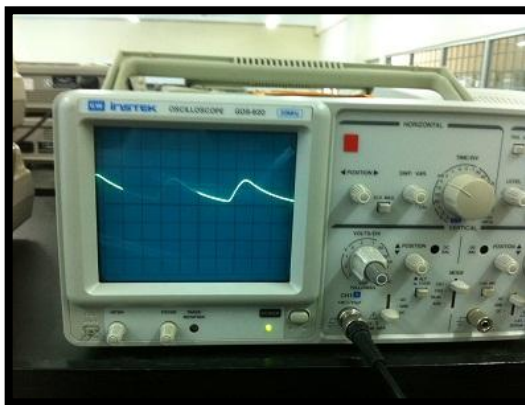

Figure: 4-16 Resultant DC voltage by using 10 μF capacitance

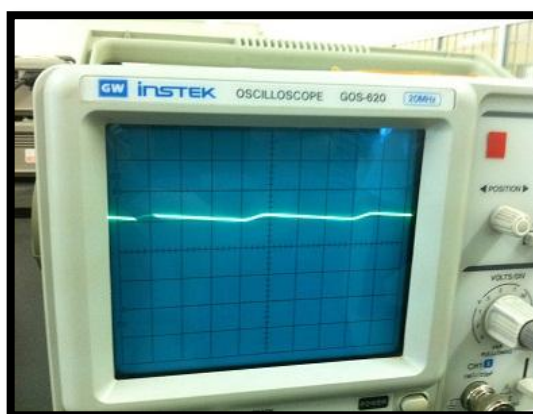

Figure: 4-17 Resultant DC voltage by using 330 μF capacitance

From result above we can conclude that the larger capacitance in the design, the smoothing the rectifier output DC voltage. A larger capacitor will reduce ripple but will cost more and will create higher peak currents in the transformer secondary and in the supply feeding it.

4.2 Combination modules testing

Experimenting of the combination modules which include current sensor, op-amp amplifier, voltage inverter, bridge rectifier and control unit to test the link function of each modules in the system. Figure below shown the configuration and connection for the system

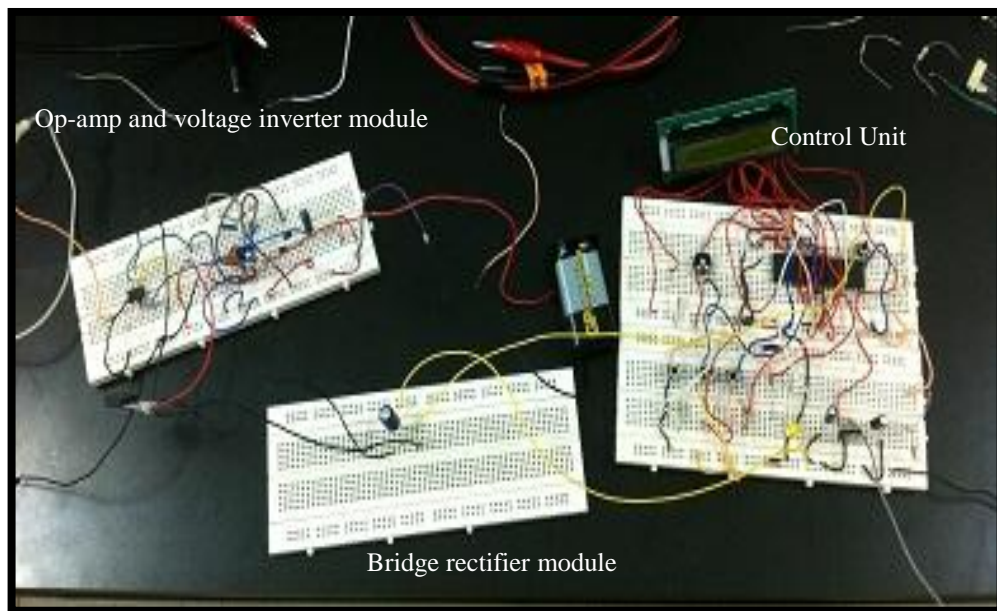

Figure 4-18 Combination modules Testing

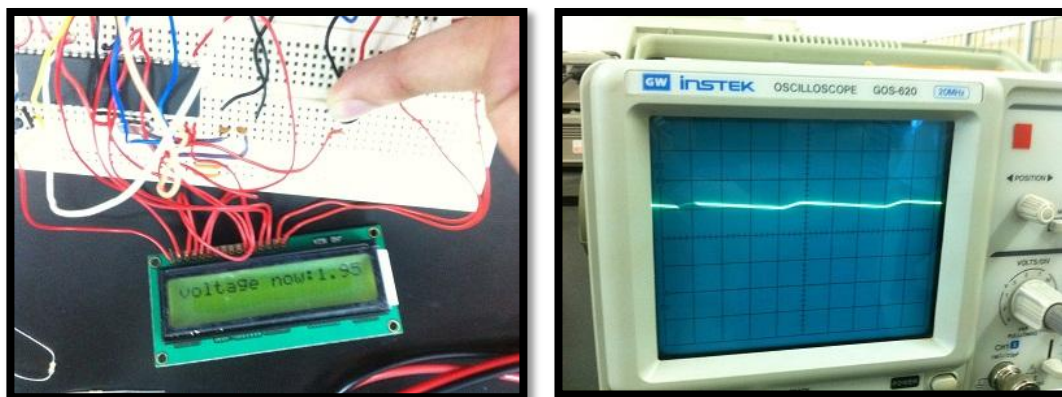

Figure 4-19 Output result of combination modules

Figure above shown the system is linked well which each other, and produced a final DC signal for the current measurement, the Control Unit detect the DC signal with little variation because of the converted dc signal is not as straight as an original DC supply, this problem can be solved by decreasing the sampling time of the ADC conversion to take the average voltage signals as reference.

4.3 Final Design Testing

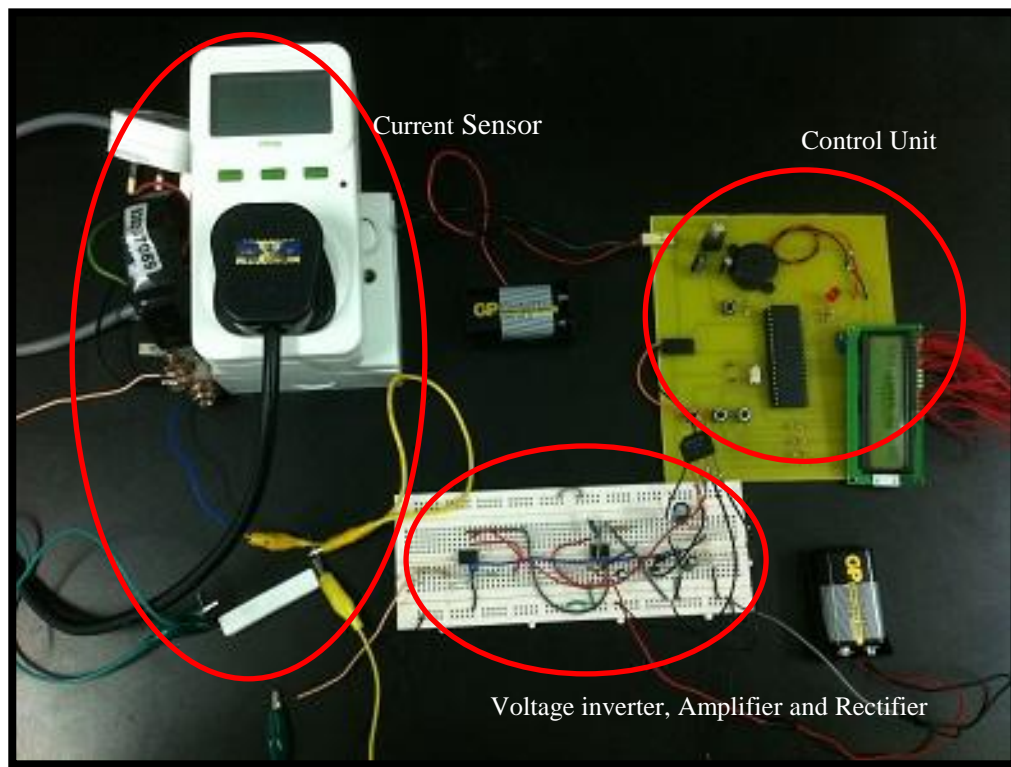

Figure 4-20 Final Design testing

The final design is tested which shown as figure above. The KillaWatt meter is use as a calibration tool / reference tool to determine the performance and efficiency of the designed system.

4.4 Performance and Accuracy

The tested result is recorded and shown as table below:

| Current measure by KillaWatt meter (Ampere) | Current measure by Designed device (Ampere) | Power measure by KillaWatt meter (Wattage) | Power measure by Designed device (Wattage) | Difference (Percentage %) |
|---|---|--|--|---------------------------|
| 2.80 A | Not applicable | 672 W | Not applicable | Not applicable |
| 3.40 A | 3.02 A | 816 W | 727.8 W | -11.170% |

| | | | | |
|--------|--------|----------|----------|----------|
| 4.20 A | 4.10 A | 1008 W | 984 W | +2.380% |
| 5.00 A | 5.50 A | 1200 W | 1320 W | -10.000% |
| 6.60 A | 7.14 A | 1584 W | 1713.6 W | +8.100% |
| 7.32 A | 7.60 A | 1756.8 W | 1824 W | +3.825% |
| 7.90 A | 8.20 A | 1896 W | 1968 W | +12.000% |

Table 4-11 Performance and accuracy

From the result, we can conclude that the accuracy of the designed product is good which only has the differences of $\pm 10\%$ by comparing with the commercial product.

The cons of the product is it only applicable for the measurement of current in the range of 3A~10A. If the current below than 3A, the device will not be applicable to detect.

The limitation and accuracy issues will be further discuss on the coming Chapter 5
Conclusion

CHAPTER 5

CONCLUSION

5.1 Limitation of the product

The limitation of the product is that is only applicable for the measurement of current in the range of 3A~10A. Unfortunately it is not really a perfect design for the home instrument power monitoring purpose which commonly in the range of 0-10A.

In the designed system, if the current below than 3A, the device are not able to detect. It is due to the limitation of the current transformer (low sensitivity) and the design which is more suitable performs for high current measurement (large capacity).

Another reason is that the output voltage from current sensor required doing AC to DC conversion must be greater than 2 diode voltage drops in the rectifier module, Once the current which pass through the CT coil is low ($< 3A$), the CT output with induce low voltage (mille volt). Even though the output is amplified but it is still not exceed of the voltage drop required of the diode.

The low current sensing can improve by adjusting the ratio of amplifying from the output of the CT coiled to get the low current reading ($< 3A$) but the high current measuring problem occurs ($> 6A$) once the amplified ratio is too high. It is because the Op-amp Clipping problem that we have discussed, the amplified voltage will be clipping at $\pm 8V$ which is the maximum supply for the battery.

Thus I have decided to design for high current measuring instead of low current, it is because of the higher power consumed device is more necessary for consumer to monitoring and avoid energy wastage problem which obtained our main objective in the project.

Secondly, the product efficiency which has a differences of $\pm 10\%$ by comparing with the commercial product. The inaccuracy problem can be explained due to a few factors.

- 1) The Transformer IV Characteristic which is not linear discussed previously, it cause the difficulty to obtain a formula for power and current calculation in the PIC calculation process.
- 2) The not ordinary AC output of the Current transformer.
- 3) The unstable Voltage DC output by the bridge rectifier.

Thirdly, the outlook and presentation of the product can be doing better. The final product look complicated and not so compact Due to the sudden changing of my hardware design the limitation of time, parts of my module are built on donut board but not PCB.

5.2 Improvement

In the hardware implementation improvement, the limitation of the product is it only applicable for the measurement of current in the range of 3A~10A due to the current sensor module. To make a wider the range of current measurement, a better current sensor needed. Instead of using such big size industrial used current transformer, it can be improved by using current transducer or PCB type current transformer which I am not able to get from the supplier. A better sensitivity and linear output current sensor needed to have low current measuring ($< 3A$) to achieve higher accuracy.

In the software implementation improvement , it can be done my adding on some extra feature such as timer and cost calculator , to getting know what is the time and cost spend by the individual device.

For system further improvement, I suggest it can be further design with each power monitoring system communicating with a main computer by wireless transmission such as Xbee technology. Thus, the user can be fully monitoring the whole house power expend and furthermore can be used for controlling (switch on and off) the individually home appliance with the wireless technology.

5.3 Conclusion

The construction of real-time power monitoring system with user feedback is one step in the larger process of reducing household energy consumption. All of the elements of the feedback system must work together towards one common goal: informing users of their energy consumption patterns such that they are continuously motivated to adjust their behavior in sustainable ways. This knowledge will allow users to identify trouble areas in their personal consumption, which in turn may lead to them removing inefficient device and becoming more aware of conservation techniques.

A real time power monitoring is developed with a measurement of current range of 3A to 10A, which capable measure up to 720W to 2400W power consumption which is in a suitable range to detect home electrical appliances. The performance and accuracy of the system is good which only has the differences of $\pm 10\%$ by comparing with the commercial tested product.

REFERENCES

1. Morton, J. (1998). *The PIC microcontroller: your personal introductory course*. Burlington: Newnes.
2. Pugh, R. (2009, March 1st). Current and Power Waveform Measurement Technique. pp. 1-2.
3. Robert Warren Erickson, D. M. (2004). *Fundamentals of power electronics*. Norway: Kluwer academic publisher.
4. Arora, M. (2010, July 7). Retrieved from eetimes: <http://www.eetimes.com/design/industrial-control/4204841/Why-a-power-factor-correction-device-is-better-suited-to-industrial-applications>
5. Faisal, M. F. *Voltage Sag Solution*.
6. Korada, P. (n.d.). *Hall Effect Current Sensors*. Retrieved from magnelab: <http://www.magnelab.com/hall.pdf>
7. M. Tavakoli Bina, A. K. (2011). *International Journal of Electrical Power & Energy Systems*, [http://www.energymanagertraining.com/announcements/EE08_result/C.Jayaraman\(1\).pdf](http://www.energymanagertraining.com/announcements/EE08_result/C.Jayaraman(1).pdf).
8. *Microchip*. (2010). Retrieved from <http://www.microchip.com/>
9. Mitzner, K. (2007). *Complete PCB design using OrCad capture and layout*. Burlington: Newnes.
10. Morton, J. (1998). *The PIC microcontroller: your personal introductory course*. Burlington: Newnes.
11. Morton, J. (2005). *The PIC microcontroller: your personal introductory course*. Newnes.
12. Nagrath. (2007). *Electronic Devices and Circuits*. PHI Learning Pvt. Ltd.
13. *National Instruments*. (2010). Retrieved from <http://www.ni.com/multisim/>
14. Nave, R. (n.d.). *hyperphysics*. Retrieved from <http://hyperphysics.phy-astr.gsu.edu/hbase/electronic/rectbr.html>
15. Pugh, R. (2009, March 1st). Current and Power Waveform Measurement Technique. pp. 1-2.

16. Robert Warren Erickson, D. M. (2004). *Fundamentals of power electronics*. Norway: Kluwer academic publisher.
17. Systems, E. P. (2009). *Electrical Power Systems*. New Age International.
18. Vincent, J. (2009). *flashscience*. Retrieved from <http://www.flashscience.com/electricity/smoothing.htm>

APPENDIX

Appendix A User Manual

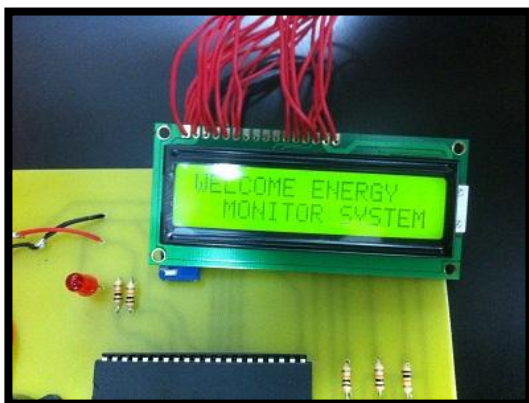

1) The program start up with Welcome Message



2) User should key in the desired current limit and press start button to start the measurement.

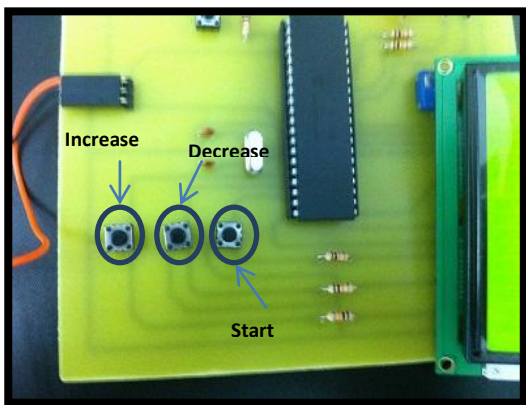

3) Left Button: Increasing the current limit
Middle Button: Decreasing the current limit
Right Button: Start the measurement

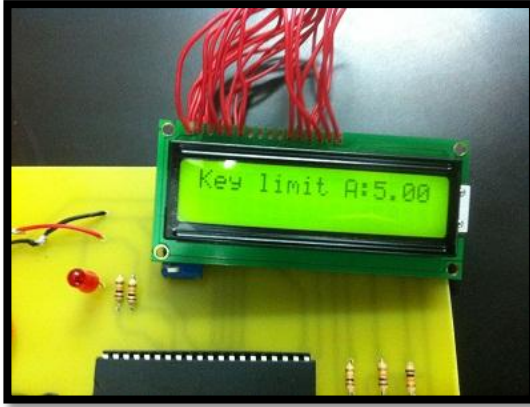

4) Figure shown that the desired current is keyed in



5) Once u start button pressed, the system will show you the value of the current measured.



6) Following by the Power consumed of the device

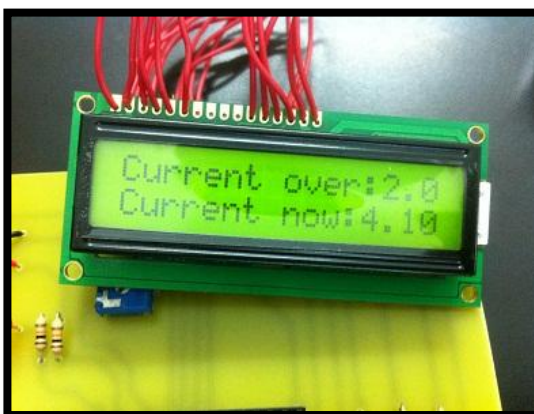

7) If the Current exceed the desired limit , LCD will show current over message and at the same time LCD and Buzzer will be turn on as a alert signal

Appendix B Time Scheduling

During the development process of the project, the uses of timeline planning are important to make sure the flows of the process are smooth and completed in time. Gantt chart is used for time scheduling management shown as figure below:

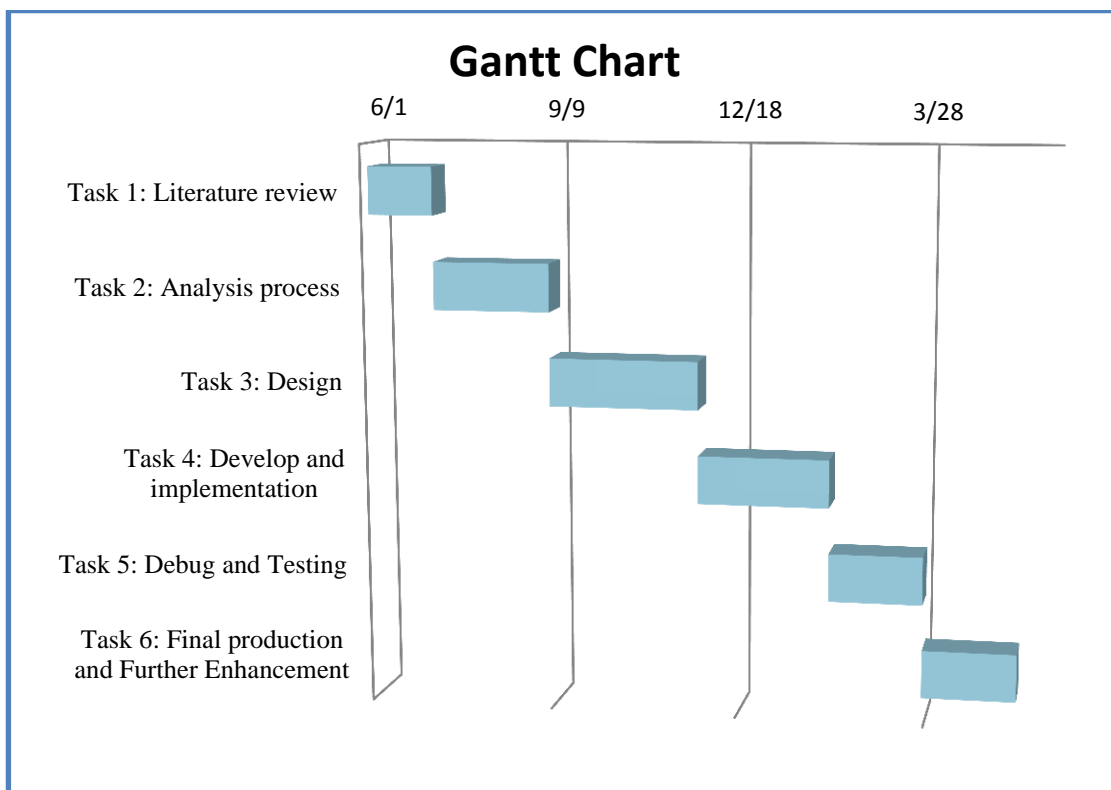

Figure 0-1 Project Gantt Chart

| | Task 1: Literature review | Task 2: Analysis process | Task 3: Design | Task 4:Develop and implementation | Task 5: Testing and Debug | Task 6:Final production and Further Enhancement |
|----------------------------|--|---|---------------------------|--|--|--|
| Start Date | 6/1/2010 | 7/6/2010 | 9/7/2010 | 11/26/2010 | 1/25/2011 | 3/16/2011 |
| End Date | 7/6/2010 | 9/7/2010 | 11/26/2010 | 1/25/2011 | 3/16/2011 | 5/15/2011 |
| Duration (days) | 35 (5 Weeks) | 63 (9 Weeks) | 80 (11 Weeks) | 70 (10 Weeks) | 50 (7 Weeks) | 50 (7 Weeks) |

Table 0-1 Project Time Scheduling